

**Gebrauchsanweisung** für Tisch- und Standkühlschränke

D

**Operating instructions** for table-height and upright refrigerators

GB

**Consignes d'utilisation** Réfrigérateurs table-top et pose libre

F

**Gebruiksaanwijzing** voor tafelmodel en stakoelkasten

NL

**Istruzione d'uso** per frigoriferi modello tavolo e verticali

I

**Instrucciones de manejo** Frigoríficos independientes

E

**Instruções de utilização** para frigoríficos sob bancada e de instalação livre

P

**Kullanma Kılavuzu** Masaüstü ve Ayaklı Buzdolaplar

TR

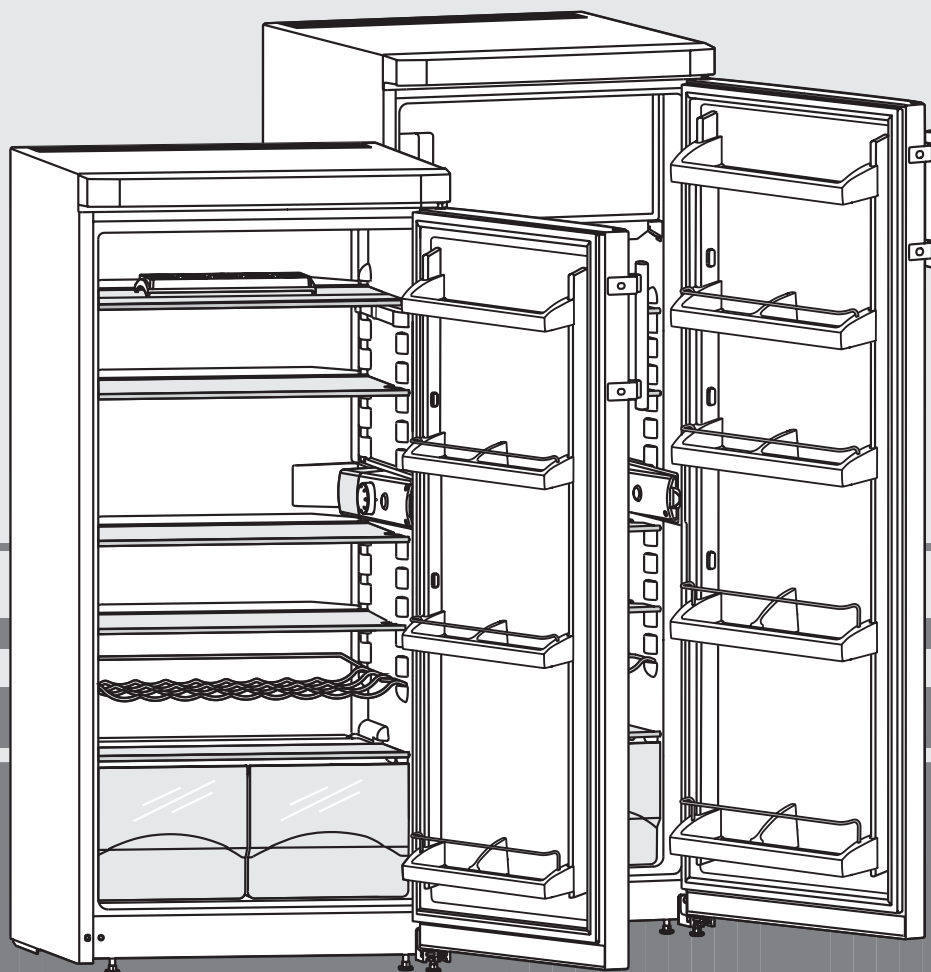

7081 897-01

K 2330/2734

4510

# 1 The appliance at a glance

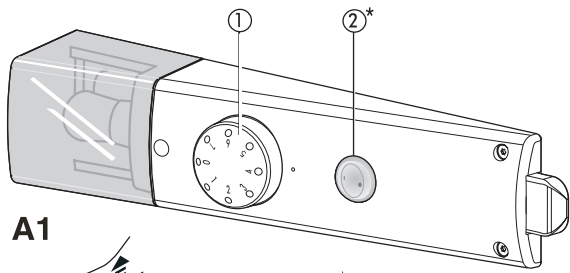

## Controls, fig. A1:

### ① On/off and temperature control

"1" = warm "7" = cold

We recommend a **medium** setting.

### ② Cool-Plus switch\*. Switch on at low room temperatures of 18°C or below.

A1

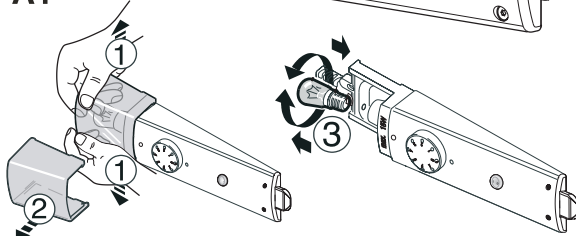

A1a

## Interior light

**Bulb data:** max. 15 W, voltage and current should agree with the details on the type plate, bulb fitting: E 14.

Replacing the bulb, fig. A1a: Switch off the appliance.

- Pull out the plug or switch off/unscrew the fuse.

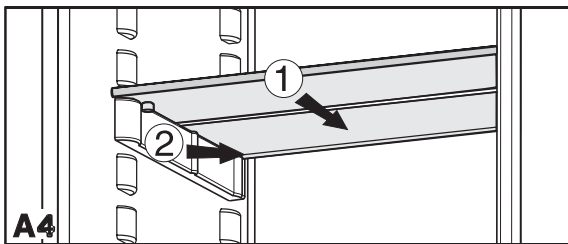
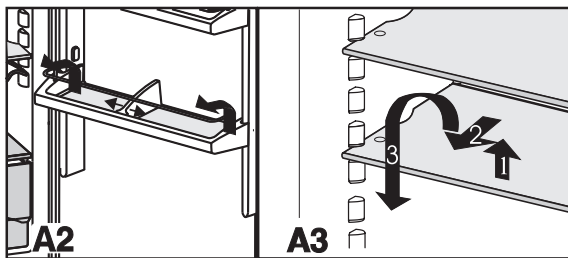

- By moving the **bottle and can holder**, you can prevent bottles from tipping over when the door is opened and closed. The holder can be removed for cleaning:
  - fig. A2: The holder slides and releases left or right along the door stops.
- You can remove all **door racks** for cleaning, fig. A2: lift rack and pull forwards.
- **Shelves\*** can be adjusted in height for different height items, fig. A3:
  - Lift the shelf, slide forwards and remove.
  - Always insert shelves with the raised edge at the back pointing upwards, otherwise food may freeze onto the rear wall.
- Fig. A4: If you need space for large bottles and containers, then simply push the front half of glass shelf\* ① back. For cleaning, the holder ② can be used to remove the half glass shelves.

## Description of appliance and equipment, fig. A

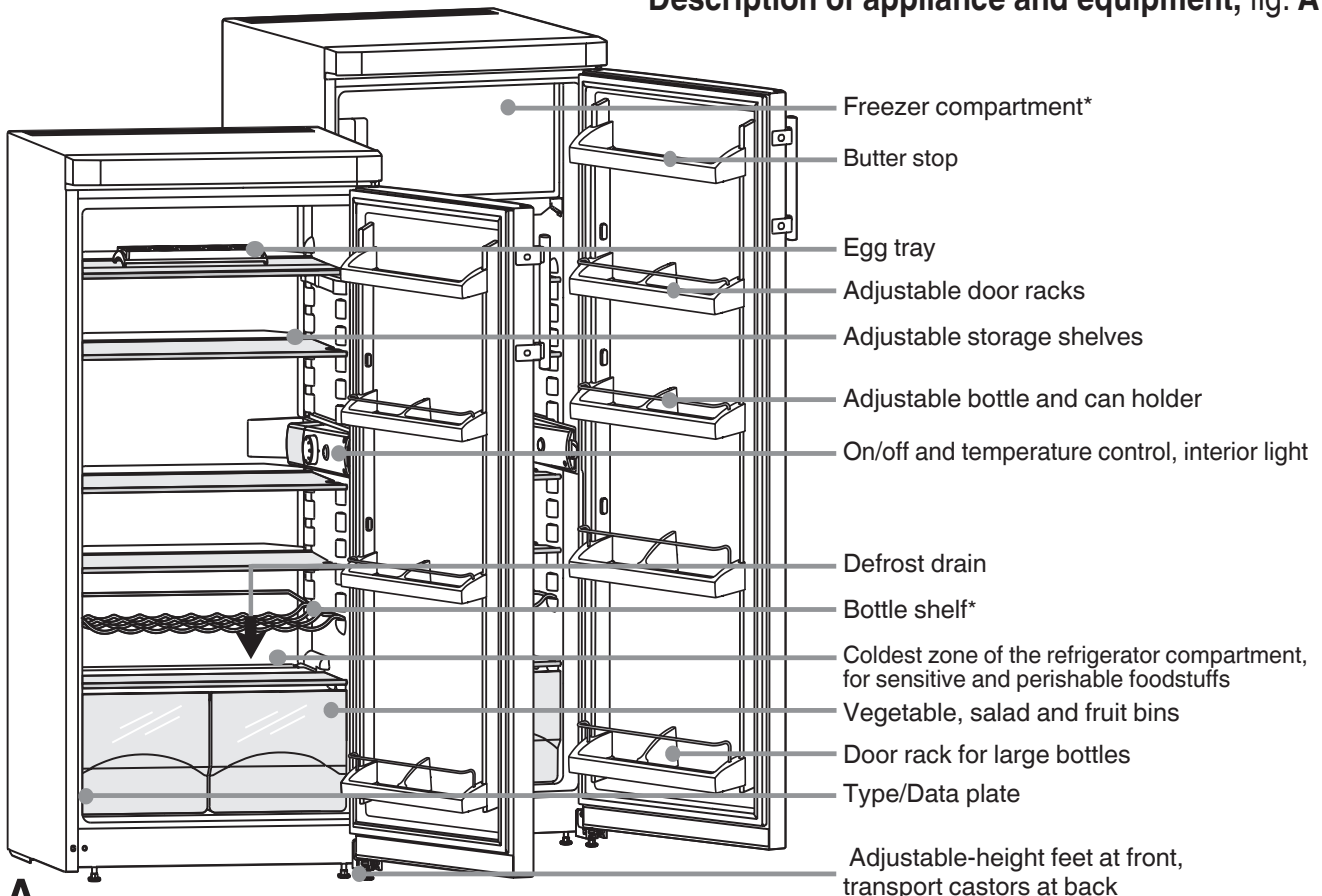

- Freezer compartment\*
- Butter stop
- Egg tray
- Adjustable door racks
- Adjustable storage shelves
- Adjustable bottle and can holder
- On/off and temperature control, interior light
- Defrost drain
- Bottle shelf\*
- Coldest zone of the refrigerator compartment, for sensitive and perishable foodstuffs
- Vegetable, salad and fruit bins
- Door rack for large bottles
- Type/Data plate
- Adjustable-height feet at front, transport castors at back

Congratulations on your purchase. In choosing this appliance you have opted for all the benefits of state-of-the-art refrigeration technology, guaranteeing you top quality, a long life span and excellent reliability.

The features on your appliance have been designed to ensure maximum convenience - day in, day out. This appliance has been manufactured with recyclable materials using an environmentally friendly process, so together you and we are making an active contribution to the preservation of our environment. To get to know all the benefits of your new appliance, please read the information contained in these operating instructions carefully. We wish you much pleasure with your new appliance.

Keep these operating instructions in a safe place and pass them on to the next owner, where applicable. The operating instructions apply to several models. Differences may therefore occur.

<b>Contents</b>	<b>Page</b>
<b>Operating instructions</b>	
<b>1 The appliance at a glance</b> .....	<b>8</b>
Contents.....	9
Safety regulations .....	9
Saving energy .....	9
<b>2 Safety instructions and warnings</b> .....	<b>10</b>
Disposal notes.....	10
Technical safety .....	10
Safety during use .....	10
Setting up.....	10
Connecting to the mains.....	10
<b>3 Refrigerator compartment</b> .....	<b>11</b>
Setting the temperature.....	11
Cool-Plus switch .....	11
Notes on cooling .....	11
<b>4 Freezer compartment</b> .....	<b>11</b>
Freezing fresh food.....	11
Notes on freezing and storage .....	11
Making ice-cubes .....	11
<b>5 Defrosting, cleaning</b> .....	<b>12</b>
<b>6 Troubleshooting</b> .....	<b>12</b>
Customer service and type plate .....	12
<b>7 Instructions for installation and modification</b> ...	<b>13</b>
Changing over door hinges .....	13
Setup Dimensions .....	13
Insertion into row of kitchen units.....	13

**Note**

- Place food inside the appliance as shown in the diagram. This allows the appliance to save energy during operation.
- Shelves, drawers and baskets are arranged for optimum energy efficiency on delivery.

**Safety regulations**



- The device is designed exclusively for the cooling of foodstuffs. The applicable statutory regulations are to be observed in the event that the device is to be used for commercial cooling of foodstuffs. The device is not suitable for the storage and cooling of drugs, blood plasma, laboratory preparations or similar medicine-related materials and products as detailed in the Medical Devices Directive 2007/47/EC. Improper use of the device can cause the stored products stored in it to be damaged or the items can be spoiled. In addition, the device is not suitable for operation in explosion-prone areas.
- The appliance is set to operate within specific ambient temperature limits according to its climate rating. These temperature limits should not be exceeded. The correct climate rating for your appliance is indicated on the type plate. This is explained as follows:

Climate rating	Set for ambient temperatures of
SN	+10°C to +32°C
N	+16°C to +32°C
ST	+16°C to +38°C
T	+16°C to +43°C

- The refrigerant circuit has been tested for leaks.
- The appliance complies with current safety regulations and EC directives 2006/95/EC and 2004/108/EC.

**Saving energy**

- Always ensure good ventilation. Do not cover ventilation openings or grille.
- Do not place appliance in areas of direct sunlight or next to a stove, heater or similar object.
- The energy consumption depends on the installation conditions, e.g. the ambient temperature.
- Keep the time the appliance is open to a minimum.
- Store food logically.
- Ensure that all food is well packed and covered for storage. This will prevent frost from forming.
- First cool warm food to room temperature before storing it.
- Defrost frozen food in the refrigerator.
- If there is a thick layer of frost in the appliance: defrost the appliance.

Accumulated dust increases the energy consumption:

- Once a year, dust the refrigerating unit together with the metal grille of the heat exchanger at the back of the appliance.



## 2 Safety instructions and warnings

### Disposal notes

The packaging is made of recyclable materials.

- Corrugated board/board
- EPS moulded parts
- Polythene sheets
- Polypropylene straps

- **Keep packaging materials away from children- polythene sheets and bags can cause suffocation!**

- Please return the packaging to an official collection point.

**Your old appliance:** This contains some reusable materials and should be disposed of properly - not simply with unsorted household refuse.

- Discarded appliances should be disabled: Remove the plug, cut through the connection cable and render the catch unusable so that children cannot become trapped inside.
- Ensure that the refrigerant circuit is not damaged when the appliance that is no longer needed is taken away for disposal.
- Details of the refrigerant can be found on the type plate.
- Appliances which are no longer needed must be disposed of in a professional and appropriate way, in accordance with the current local regulations and laws.



### Technical safety

- To prevent injury or damage to the unit, the appliance should only be transported wrapped and set up by two people.
- The refrigerant R 600a is environmentally friendly but flammable.
- Do not damage the refrigerant circuit pipes. Splashes of refrigerant can harm your eyes or ignite.
- If refrigerant escapes, remove all naked flames or sources of ignition in the vicinity of the leak, disconnect the appliance from the mains and ventilate the area well.
- In the event that the appliance is damaged, contact the supplier immediately before connecting to the mains.
- To guarantee safe operation, ensure that the appliance is set up and connected as described in these operating instructions.
- Disconnect the appliance from the mains if any fault occurs. Pull out the plug (not by pulling on the mains cable) or switch off or remove the fuse.
- **Any repairs and work on the appliance should only be carried out by the customer service department, as unauthorised work could prove highly dangerous for the user.** The same applies to changing the mains power cable.



### Safety during use

- Do not store explosives or sprays using combustible propellants such as butane, propane, pentane, etc. in the appliance. Electrical components might cause leaking gas to ignite. You can identify such sprays by the printed contents or a flame symbol.
- Only store high-percentage alcohol in tightly sealed, upright containers.
- Do not allow naked flames or ignition sources to enter the appliance.
- Do not use electrical appliances inside the appliance (e.g. steam cleaners, heaters, ice makers, etc.).
- Do not stand on the plinth, drawers or doors or use them to support anything else.
- This appliance is not intended for use by persons (including children) with reduced physical, sensory or mental capabilities or lack of experience and knowledge unless they have been given initial supervision or instruction concerning use of the appliance by a person responsible for their safety. Children should be supervised to ensure that they do not play with the appliance.
- Avoid prolonged skin contact with cold surfaces or chilled/frozen food. This could cause pain, numbness and frostbite. In the case of prolonged skin contact, protective measures should be taken, e.g. gloves should be worn.
- Do not consume food which has been stored for too long, as it could cause food poisoning.
- Special-purpose lamps (incandescent lamps, LEDs, fluorescent tubes) in the appliance serve to illuminate the appliance interior and are not suited for room illumination.



### Setting up

- When setting up/fitting ensure that the refrigerant circuit pipes are not damaged.
- Once in position, use a 10 spanner to adjust the feet so that the appliance is level and does not wobble.
- Standard EN 378 specifies that the room in which you install your appliance must have a volume of 1 m<sup>3</sup> per 8 g of R 600a refrigerant used in the appliance, so as to avoid the formation of inflammable gas/air mixtures in the room where the appliance is located in the event of a leak in the refrigerant circuit. The quantity of refrigerant used in your appliance is indicated on the type plate on the inside of the appliance.
- Always position the appliance directly up against the wall.
- **The ventilation grilles should not be obstructed.** Please note the appendix concerning installation instructions.
- Condensation may form on the outside of the refrigerator/freezer during periods of high humidity. Constant ventilation of the installation site is recommended.
- Do not place heat-emitting appliances, e.g. microwave oven, toaster, etc., on top of the refrigerator or freezer.
- In order to avoid the risk of fire, do not place any burning candles, lamps or other objects with open flames on the refrigerator/freezer.
- Fire hazard due to dampness! If live parts or the mains lead become damp this may cause short circuits.
- The appliance is designed for use in enclosed areas. Do not operate the appliance outdoors or in areas where it is exposed to splash water or damp conditions.
- CAUTION! Risk of injury and danger of damage as a result of incorrect transport!
  - Transport the appliance in a packed condition.
  - Transport the appliance upright.
  - Do not transport the appliance without assistance.
- The appliance may be moved only when it is empty.

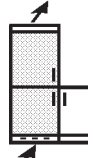

### Connecting to the mains

#### Power supply (AC) and voltage

at the operating point must comply with the details on the type plate, which is located on the inside left of the appliance, next to the vegetable bins.

- **Connect the appliance with a properly earthed fused plug and socket only.**
- The socket must be fused with a 10 A fuse or higher, it must be away from the rear of the appliance and must be easily accessible.
- Do not connect the appliance to the supply with other equipment using a distribution outlet - risk of overheating.
- When removing the mains cable from the back of the appliance, remove the  **cable holder** as well so as to avoid vibration noise.



The wires in the mains lead are coloured in accordance with the following code: green/yellow = earth, blue = neutral, brown = live.

#### Warning! This appliance must be earthed.

#### Non-rewireable plugs BS 1363

If this machine or appliance is fitted with a non-rewireable plug, the following information applies: If the socket outlets are not suitable for the plug supplied with this product, it must be cut off and an appropriate plug fitted. The plug cut from the flexible cord should be disposed of and on no account be inserted into a 13 A socket elsewhere in the house (electric shock hazard). The fuse cover **must** be re-fitted when changing the fuse, and if the fuse cover is lost the plug **must not** be used until a suitable replacement is obtained. The colour of the correct replacement cover is that of the coloured insert in the base of the plug, or the colour that is embossed in words on the base of the plug (as applicable to the design of the plug fitted). The correct rating of the replacement fuses that are ASTA approved to BS 1362 should be fitted. Replacement fuse covers may be purchased from your local electrical suppliers, electricity showroom or approved service agent.

### 3 Refrigerator compartment

You are advised to clean the appliance before switching it on for the first time (see "Cleaning").

#### Switching the appliance on and off, setting the temperature

- **On:** Turn the temperature control ①, fig. A1, clockwise from "0" to "4". The appliance is now switched on and the interior light comes on.
- **Off:** The appliance is switched off at the "0" setting. The interior light is off.
- The positions of the temperature control indicate the following:  
 "1" = **warm**, lowest cooling setting  
 "7" = **cold**, highest cooling setting
- We recommend a medium setting.
- At setting "7" it is possible to reach temperatures below "0" in the coldest zone of the fridge section.
- If you are storing frozen food and wish to ensure that the low freezing temperature is maintained, we recommend setting the temperature control to between "4" and "7".

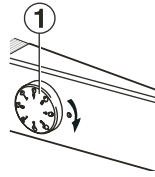

#### Cool-Plus switch\*

- **At low room temperatures of 18°C or below**, switch on the Cool-Plus switch ②, fig. A1, on the temperature control housing. This will ensure that the freezer compartment stays at the right temperature.
- **At normal room temperatures of above 18°C**, it is not necessary to switch on the Cool-Plus switch; it should stay switched off.

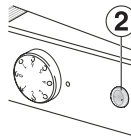

NB: Please note that the temperature inside the appliance is affected by the room temperature, the place where the appliance is installed, the frequency with which the door is opened and how full the appliance is.

#### Notes on cooling

- As a result of the circulation of the air, the temperature in the refrigerator compartment is not uniform. This can have advantages for storing different types of food.
- Just above the vegetable bins and at the back of the refrigerator, the air is colder, ideal for raw meat or cold meats.
- At the top front of the compartment and in the door, the air is warmer, making it ideal for cheese and for spreadable butter.
- Store food so that the air can circulate freely; do not place items too close together, and keep at least 2 cm away from the interior light.
- Always store food in closed containers or wrapped.
- Reusable plastic, metal, aluminium and glass containers or cling-film can be used for wrapping.
- Always store food which gives off or is sensitive to ethylene gases such as fruit, vegetables and salads separately or wrapped in order not to affect their storage life; e.g. do not store tomatoes together with kiwis or cabbage.

### 4 Freezer compartment\*

You can store frozen food for several months, prepare ice-cubes and freeze fresh food in the ❄️ freezer compartment at temperatures of -18°C and lower (medium temperature setting or lower).

**NB:** The **air temperature** in the compartment, measured with a thermometer or other measuring equipment, may fluctuate. However this will have little effect on the frozen food when the compartment is full. The core temperature of the frozen food will be the average of these values.

#### Making ice-cubes

- Fill the **ice-cube tray**\* three-quarters full with water and freeze. The ice-cubes can be removed from the tray by twisting or by holding upside down for a short time under running water.

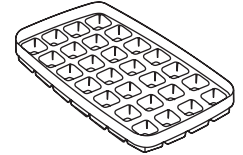

#### Freezing fresh food

Fresh food should be frozen to the core as rapidly as possible. This ensures that the nutritional value, vitamins, appearance and flavour of the food remain intact. Larger quantities of fresh food should be frozen as follows:

- Approx. **24 hours** before placing the food in the freezer, turn the temperature control to a **medium to cold setting** (approx. 6).
- Switch on Cool-Plus ②. Frozen food already stored will receive an additional boost.
- Insert the fresh food. The maximum amount of food which can be frozen in 24 hours is shown on the type plate ("Freezing capacity ... kg/24h")\*. Spread out the fresh food on the bottom of the freezer compartment as much as possible and do not allow it to come into contact with frozen food already stored.
- The freshly frozen food will be thoroughly frozen after 24 hours.
- Set the temperature control back to its previous setting. Switch off Cool-Plus ② again. The freezing procedure is complete and the appliance will return to its normal cooling function.

#### Notes on freezing and storage

- You can put foods that are already frozen and up to 1 kg of fresh foods per day **straight** into the cold freezer compartment.
- Once food has been thawed it should be prepared and not simply frozen again.
- As a guideline for the storage time, the following applies to various foodstuffs in the freezer compartment:

Ice cream	2 to 6 months
Sausage, ham	2 to 6 months
Bread, cakes and pastries	2 to 6 months
Game, pork	6 to 10 months
Fish, oily	2 to 6 months
Fish, lean	6 to 12 months
Cheese	2 to 6 months
Poultry, beef	6 to 12 months
Vegetables, fruit	6 to 12 months

\* Depending on model and options

## 5 Defrosting, cleaning

### Defrosting

Appliances without freezer compartment defrost automatically. The moisture occurring at the back wall of the refrigerator is carried outside the refrigerator into an evaporating dish through the defrost water channel. The defrost water is evaporated by the compressor heat - water droplets on the rear wall depend on function and are completely normal.

- At least ensure that the defrost water can always flow out of through the outlet hole via the vegetable bin to the rear wall (arrow in Fig. A) unhindered.

### Freezer compartment\*

**Do not use any electrical heating or steam cleaning appliances, defrosting sprays, open flames or metal objects to remove ice. Risk of injury and damage to the appliance.**

To accelerate the defrosting process, put a pan with warm, not boiling water into the compartment.

How to defrost:

- Switch off the appliance: Disconnect from the mains or - Turn the temperature setting to the "0" position.
- Remove frozen goods, put into newspaper or blankets and stored in a cool place.
- Leave the compartment and appliance door open during the defrosting process.
- Collect defrosting water with a sponge or cloth. Then clean the appliance.

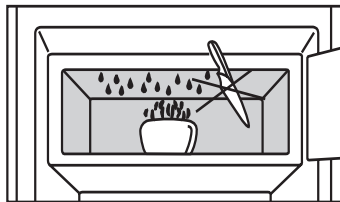

### Cleaning

- **Before cleaning, always switch off the appliance. Disconnect from the mains or un-screw or switch off the fuse.**
- Wash shelves, glass plates and other options by hand.
- Clean the outer walls, inside and appliance by hand with lukewarm water and a little detergent. Because of the risk of injury and damage to the appliance, steam cleaning equipment should not be used.
- Never use abrasive or scouring sponges. Do not use concentrated cleaning agents and never use abrasive or acid cleaners or chemical solvents.
- We recommend using a soft cloth and an all-purpose cleaner with a neutral pH value. Only use food safe cleaning materials inside the appliance.
- **For stainless-steel appliances\*:**
  - Clean the side panels and door surfaces with a clean and soft cloth. If necessary, use a moist cloth (water + detergent). Alternatively, use a micro-fibre cloth.
- Ensure that no cleaning water penetrates into the electrical components, drain gully\* or ventilation grilles. Wipe the appliance dry.
- Do not damage or remove the type plate on the inside of the appliance. It is very important for servicing purposes.
- Clean the **drain hole** on the rear wall above the vegetable bins often Fig. A, arrow. If necessary, clean with a thin object, e.g. a cotton swab or similar.
- Ensure that none of the wires or other components are dislodged, bent or damaged.
- Then connect/switch on the appliance.

If the appliance is to be left switched off for any length of time, empty the appliance, disconnect from the mains, clean as described above and leave the door open so as to avoid odours.



## 6 Troubleshooting

Your appliance is designed and manufactured in such a way as to provide fault-free operation and a long service life. Nevertheless, if a fault should occur during operation, please check whether the fault is due to incorrect operation. In this case we have to charge you for any costs incurred also within the warranty period.

You can eliminate the following faults yourself by checking the possible causes:

### Fault possible cause and remedy

#### Appliance not working

- Is the appliance switched on properly?
- Is the mains plug properly inserted in the socket?
- Is the socket fuse intact?

#### The interior light does not come on

- Is the refrigerator compartment switched on?
- The bulb is defective. Change the bulb as described in "Interior light".

Interior light on when Cool-Plus activated:

- This is necessary from a technical point of view and is quite normal.
- To be able to ensure that the Cool-Plus function works entirely as it should, the defective light bulb should be replaced as soon as possible.

#### Loud running noise

- Is the appliance standing firmly on the floor, or does the compressor cause nearby items of furniture or objects to vibrate? If necessary, move the appliance slightly, align by adjusting the adjustable feet, or move bottles and containers apart.
- **Burbling noises** are normal. These are caused by the refrigerant flowing round the refrigerant circuit.

A short **clicking sound**: This will be heard whenever the refrigeration unit (the motor) switches on or off automatically.

**Motor noise**: This will be slightly louder for a brief period when the refrigeration unit switches on.

#### Temperature is not cold enough

- Is the temperature controller set correctly? (Set colder as needed).
- Is the appliance door properly closed?
- Is there sufficient ventilation? Unblock ventilation grill as needed.
- Is the ambient temperature too hot? (see "Conditions" section)
- Has the appliance been open too often or for too long?
- Wait as needed, whether the required temperature has been set on its own.

### Customer service and type plate

If none of the above causes apply and you cannot rectify the fault yourself, please contact your nearest customer service department (see enclosed list for addresses). State the **type designation** ①, **service number** ② and **appliance number** ③ as given on the type plate, so as to ensure rapid, accurate servicing. The type plate is located inside the appliance on the left-hand side.

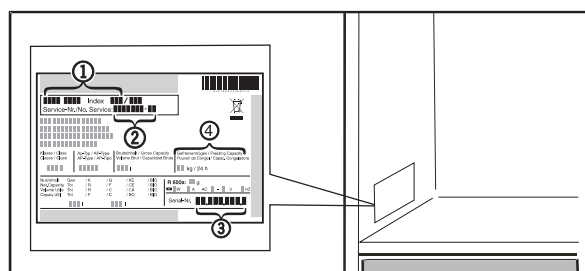

# 7 Instructions for installation and modification

Before reading, please fold out and refer to the illustrated back page.



## Changing over door hinges

Fig. T: You can change over the door hinges if necessary. Follow the order of the positions illustrated in fig. T/T1.

## Setup Dimensions

The appliance dimensions can be found on the fig S below and in the following table.

Model Nominal width	Appliance dimensions (mm)							
	a	c	c'	d	e	e'	g	h
K 2330	550	559	591	1129	628	660	614	1175
K 2734	550	559	591	1129	628	660	614	1420

## Insertion into row of kitchen units

Fig. U: The appliances can be installed in a row of kitchen units. To adapt the height of the appliance to the surrounding furniture a top unit ① can be added.

A gap of at least 50 mm depth must be provided behind and along the entire width of this unit so as to ensure sufficient ventilation. The area of ventilation underneath the ceiling should be at least 300 cm<sup>2</sup>. The greater the area the more economically the appliance will run.

- When setting up the appliance next to a wall ④, a minimum distance of 50 mm must be provided on the hinge side between the appliance and the wall.

- ① top unit
- ② refrigerator/freezer
- ③ kitchen unit side panel
- ④ wall

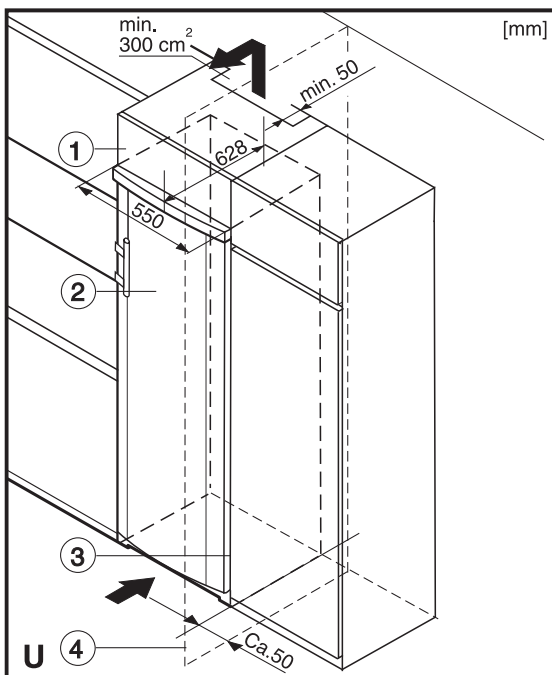

All types and models are subject to continuous improvement and the manufacturer therefore reserves the right to make modifications in the shape, equipment and technology.

