

Gebrauchsanweisung für Kühl-Gefrier-Kombination

Operating instructions for fridge-freezer combination

Consignes d'utilisation pour combiné réfrigérateur-congérateur

Gebruiksaanwijzing voor koel-vries-combinatie

Istruzione d'uso per combinazione frigo-congelatore

Instrucciones de manejo para combinado frigorífico-congelador

Kullanım Kılavuzu Soğutucu-Dondurucu-Kombinasyonu

D

GB

F

NL

I

E

TR

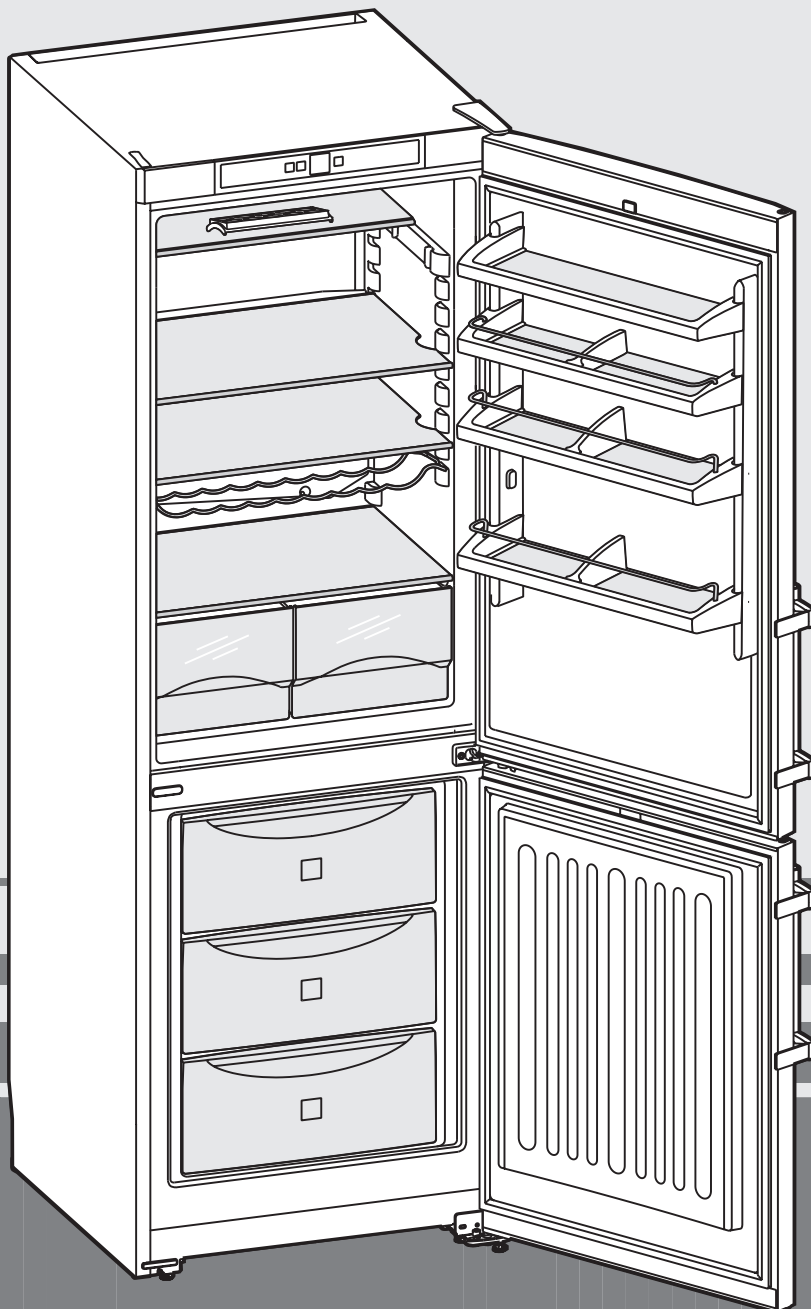

7081 933-04

CU/CUP 31../35../40..

0111

1 The appliance at a glance

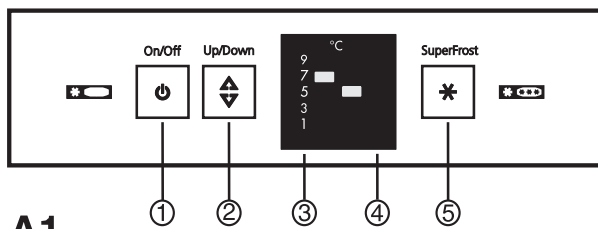

Operating controls, fig. A1

- ① On/Off button, fridge section
- ② Up/Down button
- ③ Temperature display, fridge section
- ④ Temperature display for freezer section
- ⑤ SuperFrost button

A1

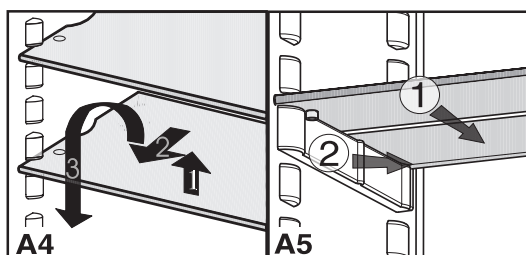
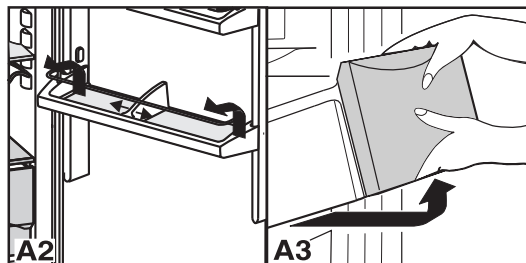

- By moving the **bottle and can holder**, you can prevent bottles from tipping over when the door is opened and closed. The holder can be removed for cleaning:
 - fig. **A2**: The holder slides and releases left or right along the door stops.
- You can remove all **door racks** for cleaning, fig. **A2**: lift rack and pull forwards.
- **The shelves*** can be adjusted according to height of frozen food, fig. **A4**.
 - Lift the shelf, slide forwards and remove.
 - Always insert shelves with the raised edge at the back pointing upwards, otherwise food may freeze onto the rear wall.
- **Removing drawers**: Pull forward until the drawer stops and lift out, fig. **A3**.
- Fig. **A5**: If you need space for large bottles and containers, then simply push the front half of glass shelf ① back. For cleaning, the holder ② can be used to remove the half glass shelves.

Rating plate specifications Fig. A6

- ① Appliance designation
- ② Service number
- ③ Appliance number
- ④ Freezing capacity ... kg/24hrs.

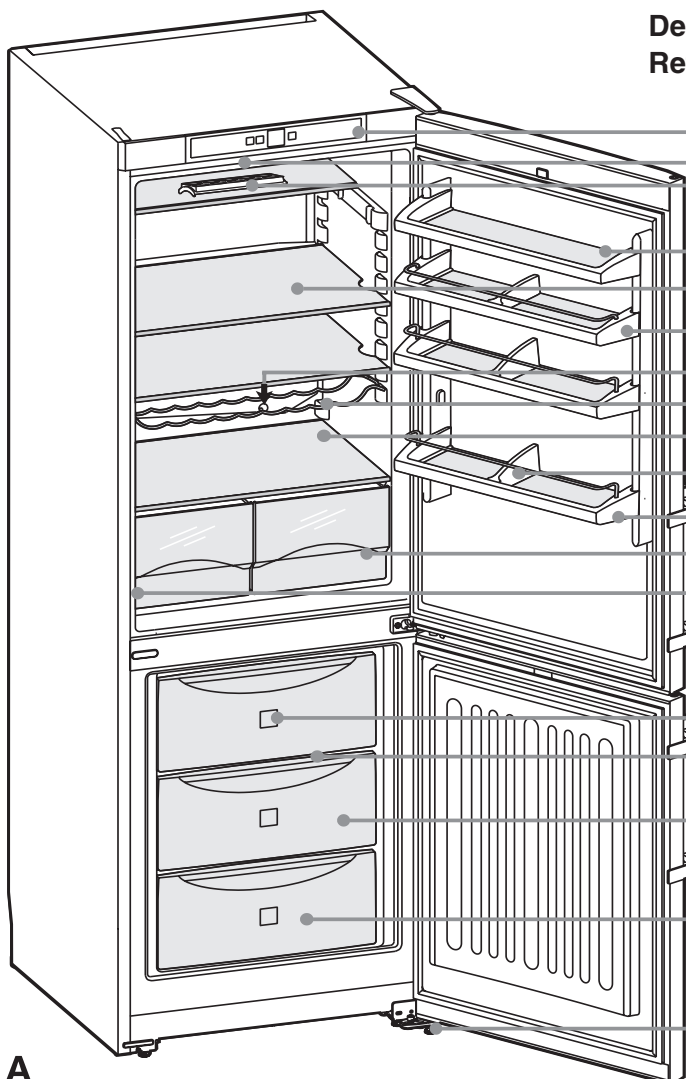
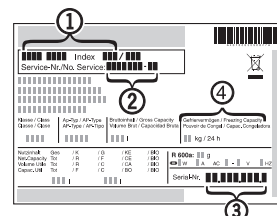

Description of appliance and equipment, Fig. A

Refrigerator compartment, approx. 5 °C

- Operating controls
- Ceiling lighting
- Egg tray
- Butter stop
- Adjustable storage shelves
- Adjustable door racks
- Defrost drain
- Bottle shelf*
- Coldest zone of the refrigerator compartment, for sensitive and perishable foodstuffs
- Adjustable bottle and can holder
- Door rack for large bottles
- Vegetable, salad and fruit bins
- Rating plate

Freezer compartment, approx. -18 °C

- Information system*
- VarioSpace*
- High drawers
- Ice-cube tray*
- Adjustable-height feet at front, transport castors at back

A

* depending on model and options

Congratulations on your purchase. Your appliance offers you all the advantages of modern refrigeration technology, guaranteeing you high quality, a long service life and high reliability. The features on your appliance have been designed to ensure maximum convenience - day in, day out.

This appliance has been manufactured with recyclable materials using an environmentally friendly process, so together you and we are making an active contribution to the preservation of our environment.

To familiarise yourself with all the advantages your new appliance has to offer, please read the information contained in these operating instructions carefully.

We wish you much pleasure with your new appliance.

Keep these operating instructions in a safe place and pass them on to the next owner, where applicable. The operating instructions apply to several models. Differences may therefore occur.

Contents	Page
Operating instructions	
1 The appliance at a glance	10
Contents.....	11
Safety regulations	11
Saving energy	11
2 Safety instructions and warnings	12
Disposal notes.....	12
Technical safety.....	12
Safety during use	12
Setting up.....	12
Connecting to the mains	12
3 Putting into operation and controls	13
Switching the appliance on and off	13
Adjusting the temperature.....	13
Temperature display.....	13
4 Refrigerator compartment	14
Arrangement of food.....	14
Interior light.....	14
5 Freezer compartment	14
Making ice-cubes	14
SuperFrost.....	14
Notes on freezing and storage.....	15
6 Defrosting	15
6 Cleaning	16
7 Troubleshooting	16
Customer service and type plate	16
8 Instructions for installation and modification	
Changing over door hinges	17
Insertion into row of kitchen units.....	17

Safety regulations §

- The device is designed exclusively for the cooling of foodstuffs. The applicable statutory regulations are to be observed in the event that the device is to be used for commercial cooling of foodstuffs. The device is not suitable for the storage and cooling of drugs, blood plasma, laboratory preparations or similar medicine-related materials and products as detailed in the Medical Devices Directive 2007/47/EC. Improper use of the device can cause the stored products stored in it to be damaged or the items can be spoiled. In addition, the device is not suitable for operation in explosion-prone areas.
- The appliance is set to operate within specific ambient temperature limits according to its climate rating. These temperature limits should not be exceeded. The correct climate rating for your appliance is indicated on the type plate. This is explained as follows:

Climate rating	set for ambient temperatures of
SN	+10°C to +32°C
N	+16°C to +32°C
ST	+16°C to +38°C
T	+16°C to +43°C

- The refrigerant circuit has been tested for leaks.
- The appliance complies with current safety regulations and EC directives 2006/95/EC and 2004/108/EC.

Saving energy

- Always ensure good ventilation. Do not cover ventilation openings or grille.
- Do not place appliance in areas of direct sunlight or next to a stove, heater or similar object.
- The energy consumption depends on the installation conditions, e.g. the ambient temperature.
- Keep the time the appliance is open to a minimum.
- The lower the temperature setting, the higher the power consumption.
- Store food logically.
- Ensure that all food is well packed and covered for storage. This will prevent frost from forming.
- Remove food as needed in order that it does not warm too much.
- First cool warm food to room temperature before storing it.
- Defrost frozen food in the refrigerator.
- If there is a thick layer of frost in the appliance: defrost the appliance.

Accumulated dust increases the energy consumption:

- Once a year, dust the refrigerating unit together with the metal grille of the heat exchanger at the back of the appliance.



Note

- Place food inside the appliance as shown in the diagram. This allows the appliance to save energy during operation.
- Shelves, drawers and baskets are arranged for optimum energy efficiency on delivery.

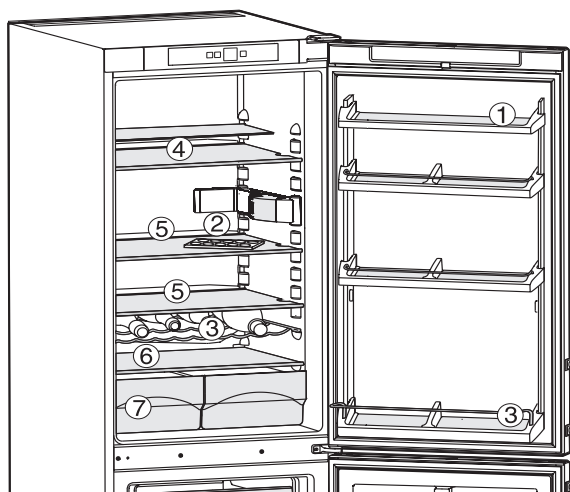

B
Example of food arrangement Fig. B

- 1 butter, cheese
- 2 eggs
- 3 cans, drinks, bottles
- 4 preserves, baked goods
- 5 dairy products
- 6 coldest zone of refrigerator compartment: sensitive foods, meat/sausages, fish, raw milk products, convenience foods
- 7 fruit, vegetables, salad

2 Safety instructions and warnings

Disposal notes

The packaging is made of recyclable materials.

- Corrugated board/board
- EPS moulded parts
- Polythene sheets
- Polypropylene straps

- **Keep packaging materials away from children - polythene sheets and bags can cause suffocation!**
- Please return the packaging to an official collection point.

Your old appliance: This contains some reusable materials and should be disposed of properly - not simply with unsorted household refuse.

- Discarded appliances should be disabled: Remove the plug, cut through the connection cable and render the catch unusable so that children cannot become trapped inside.
- Ensure that the refrigerant circuit is not damaged when the appliance that is no longer needed is taken away for disposal.
- Details of the refrigerant can be found on the type plate.
- Appliances which are no longer needed must be disposed of in a professional and appropriate way, in accordance with the current local regulations and laws.



Technical safety

- To prevent injury or damage to the unit, the appliance should only be transported wrapped and set up by two people.
- The refrigerant R 600a is environmentally friendly but flammable.
- Do not damage the refrigerant circuit pipes. Splashes of refrigerant can harm your eyes or ignite.
- If refrigerant escapes, remove all naked flames or sources of ignition in the vicinity of the leak, disconnect the appliance from the mains and ventilate the area well.
- In the event that the appliance is damaged, contact the supplier immediately before connecting to the mains.
- To guarantee safe operation, ensure that the appliance is set up and connected as described in these operating instructions.
- In the event of a fault, disconnect the appliance from the mains: disconnect mains plug (do not pull on the connection cable) or trigger or unscrew fuse.
- Any repairs and work on the appliance should only be carried out by the customer service department, as unauthorised work could prove highly dangerous for the user. The same applies to changing the mains power cable.



Safety during use

- Do not store explosives or sprays using combustible propellants such as butane, propane, pentane, etc. in the appliance. Electrical components might cause leaking gas to ignite. You can identify such sprays by the printed contents or a flame symbol.
- Only store high-percentage alcohol in tightly sealed, upright containers.
- Do not allow naked flames or ignition sources to enter the appliance.
- Do not use electrical appliances inside the appliance (e.g. steam cleaners, heaters, ice makers, etc.).
- Do not stand on the plinth, drawers or doors or use them to support anything else.
- This appliance is not intended for use by persons (including children) with reduced physical, sensory or mental capabilities or lack of experience and knowledge unless they have been given initial supervision or instruction concerning use of the appliance by a person responsible for their safety. Children should be supervised to ensure that they do not play with the appliance.
- Avoid prolonged skin contact with cold surfaces or chilled/frozen food. This could cause pain, numbness and frostbite. In the case of prolonged skin contact, protective measures should be taken, e.g. gloves should be worn.
- Do not consume food which has been stored for too long, as it could cause food poisoning.
- Special-purpose lamps (incandescent lamps, LEDs, fluorescent tubes) in the appliance serve to illuminate the appliance interior and are not suited for room illumination.



Setting up

- When setting up/fitting ensure that the refrigerant circuit pipes are not damaged.
- Once in position, use a 10 spanner to adjust the feet so that the appliance is level and does not wobble.
- Standard EN 378 specifies that the room in which you install your appliance must have a volume of 1 m³ per 8 g of R 600a refrigerant used in the appliance, so as to avoid the formation of inflammable gas/air mixtures in the room where the appliance is located in the event of a leak in the refrigerant circuit. The quantity of refrigerant used in your appliance is indicated on the type plate on the inside of the appliance.
- Always position the appliance directly up against the wall.
- **The ventilation grilles should not be obstructed.** Please note the appendix concerning installation instructions.
- Condensation may form on the outside of the refrigerator/freezer during periods of high humidity. Constant ventilation of the installation site is recommended.
- Do not place heat-emitting appliances, e.g. microwave oven, toaster, etc., on top of the refrigerator or freezer.
- Keep burning candles, lamps and other items with naked flames away from the appliance so that they do not set the appliance on fire.
- Fire hazard due to dampness! If live parts or the mains lead become damp this may cause short circuits.
- The appliance is designed for use in enclosed areas. Do not operate the appliance outdoors or in areas where it is exposed to splash water or damp conditions.
- **CAUTION!** Risk of injury and danger of damage as a result of incorrect transport!
- Transport the appliance in a packed condition.
- Transport the appliance upright.
- Do not transport the appliance without assistance.
- The appliance may be moved only when it is empty.

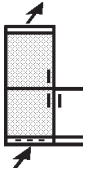

Connecting to the mains

Power supply (AC) and voltage

at the operating point must comply with the details on the rating plate, which is located on the inside left of the appliance, next to the vegetable bins.

- **Connect the appliance with a properly earthed fused plug and socket only.**
- The socket must be fused with a 10 A fuse or higher, it must be away from the rear of the appliance and must be easily accessible.
- Do not connect the appliance to the supply with other equipment using a distribution outlet - risk of overheating.
- When removing the mains cable from the back of the appliance, remove the **cable holder** as well so as to avoid vibration noise.



The wires in the mains lead are coloured in accordance with the following code:

green/yellow = earth,
blue = neutral,
brown = live.

Warning! This appliance must be earthed.

Non-rewireable plugs BS 1363

If this machine or appliance is fitted with a non-rewireable plug, the following information applies: If the socket outlets are not suitable for the plug supplied with this product, it must be cut off and an appropriate plug fitted. The plug cut from the flexi-ble cord should be disposed of and on no account be inserted into a 13 A socket elsewhere in the house (electric shock hazard). The fuse cover **must** be re-fitted when changing the fuse, and if the fuse cover is lost the plug **must not** be used until a suitable replacement is obtained. The colour of the correct replacement cover is that of the coloured insert in the base of the plug, or the colour that is embossed in words on the base of the plug (as applicable to the design of the plug fitted).

The correct rating of the replacement fuses that are ASTA approved to BS 1362 should be fitted. Replacement fuse covers may be purchased from your local electrical suppliers, electricity showroom or approved service agent.

3 Putting into operation and controls

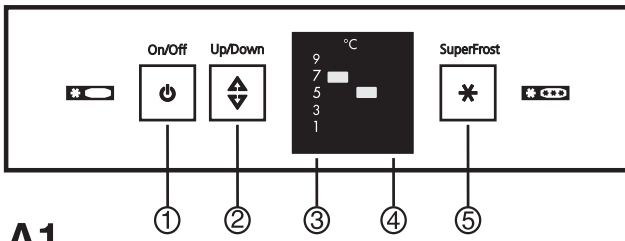

Temperature display

The following are displayed in normal mode:

- The set fridge temperature ③

The display flashes:

- The temperature setting is being changed
- The temperature has risen by several degrees.

A1

You are advised to clean the appliance before switching it on for the first time (see "Cleaning").

Put the appliance into operation approximately 4 hours before loading with frozen food for the first time. Only insert frozen food when the freezer compartment is cold.

Switching the appliance on and off Fig. A1

Switching on:

To switch on the entire appliance you only need to switch on the fridge section.

When the fridge section is switched on, the freezer section is switched on, too.

- Briefly press the On/Off button ① .
The temperature displays light up. The fridge and freezer sections are switched on.

Switching off:

- To switch off the entire appliance you only need to switch off the fridge section. The freezer section is automatically switched off, too.
- Press the On/Off button ① for approx. 2s.
- The temperature displays are dark. The appliance is switched off.
- The interior lighting is dark.

Adjusting the temperature Fig. A1

● Fridge section:

The temperature depends on the following factors:

- The frequency of opening the door
 - The room temperature of the installation location
 - The type, temperature and quantity of the frozen food
- Recommended temperature setting: 5 °C.

The temperature can be changed progressively. When the setting 1 °C is reached, it begins again at 9 °C.

- Press the adjustment button ② until the LED of the desired temperature lights up.

Note: Pressing the Up/Down button once activates the nominal value adjustment.

By pressing the adjustment button for a long time, a colder setting is adjusted within a small temperature range (e.g.: between ``5`` and ``7``), but it is not visible on the display.

● Freezer section:

The recommended temperature setting of 5°C in the cooling section will produce an average temperature of approx. -18°C in the freezer section.

4 Refrigerator compartment

Arrangement of food

Due to the natural air circulation in the refrigerator compartment, different temperature ranges result, which are beneficial for the storage of different foods. Just above the vegetable bins and at the back of the refrigerator, the air is colder, ideal for raw meat or cold meats; at the top front of the compartment and in the door, the air is warmer, making it ideal for cheese and for spreadable butter.

Notes on refrigerating

- Store food so that the air can circulate freely; do not place items too close together. *Do not cover the ventilator air slots* on the rear wall* - important for refrigerating capacity!
- Always keep foods which easily give off or take on odours or flavours, and liquids, in closed containers or covered.
- Always store food which gives off or is sensitive to ethylene gases such as fruit, vegetables and salads separately or wrapped in order not to affect their storage life; e.g. do not store tomatoes together with kiwis or cabbage.

Changing the interior lighting

Light-bulb specifications:

max. 25 W

Socket: E 14

The current and voltage types should agree with the information on the type plate

- Switch off the appliance. **Remove the mains plug, or trigger or remove the fuse.**
- Hold the lamp cover at the front according to the illustration, and detach at the rear.
- Replace the bulb.
- Re-install the cover.

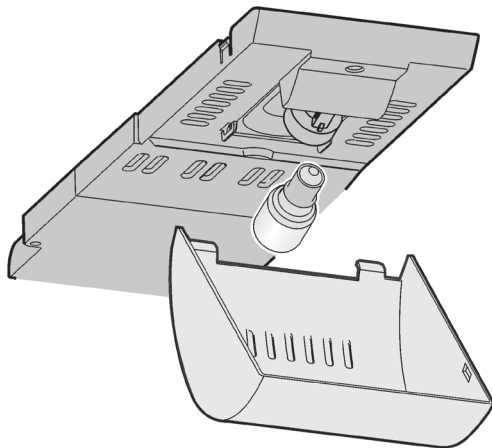

5 Freezer compartment

Making ice-cubes

- Fill the **ice-cube tray*** three-quarters full with water and freeze. The ice-cubes can be removed from the tray by twisting or by holding upside down for a short time under running water.

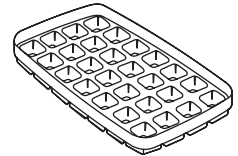

SuperFrost

The *fresh* foods should be frozen to the core as quickly as possible and frozen foods already stored be given a "cold reserve". This is enabled by the SuperFrost system. This is the best way of maintaining the nutritional value, appearance and flavour of frozen foods.

- The maximum amount of fresh food which can be frozen in 24 hours is shown on the rating plate ("Freezing capacity ... kg/24h"), fig. **A4**, pos. ④. The maximum quantity of frozen food varies according to model and climatic class.

Freezing with SuperFrost

Fig. A1/⑤

You do *not* have to switch SuperFrost on:

- when inserting already frozen foods,
- when freezing up to approx. 2 kg of fresh food daily.
- Press SuperFrost button ⑤ briefly, so that the LED lights up.
- The freezing temperature decreases, the appliance works with the greatest possible freezing capacity.
- With a smaller amount of food to be frozen, wait/pre-freeze for approx 6 hours - normally sufficient, with the *maximum* quantity, see freezing capacity on rating plate, approx. 24 hours.
- Then insert the fresh food.
- The SuperFrost function can be quit manually by briefly pressing button ⑤, if not:
- SuperFrost switches off **automatically** after approximately 65 hours.
- the SuperFrost button is dark
- the temperature range set for normal mode lights up in the temperature display.
- the appliance continues in normal energy-saving mode.
- In order to reach the maximum freezer performance, warm food must be placed directly on the shelves, not in the drawers, or stored in direct contact to the inner side walls.



5 Freezer compartment

Notes on freezing and storage

- As a guideline for the storage time, the following applies to various foodstuffs in the freezer compartment:

Ice cream	2 to 6 months
Sausage, ham	2 to 6 months
Bread, cakes and pastries	2 to 6 months
Game, pork	6 to 10 months
Fish, oily	2 to 6 months
Fish, lean	6 to 12 months
Cheese	2 to 6 months
Poultry, beef	6 to 12 months
Vegetables, fruit	6 to 12 months

- **Suitable packing materials** are conventional freezer bags, reusable plastic, metal and aluminium containers.
- Do not allow fresh food to be frozen to come into contact with food already frozen. Always insert packaging in a dry condition to avoid packaging freezing together.
- Always provide packaging with date and contents and do not exceed the recommended storage time of the frozen food, in order to prevent reductions in quality.
- Always package food which you freeze yourself in suitable portions for your household. So that the food freezes quickly through to the core, the following quantities per package should not be exceeded:
 - Fruit and vegetables up to 1 kg,
 - meat up to 2.5 kg.
- After washing and portioning, blanch **vegetables** (immerse in boiling water for 2-3 minutes, then remove and cool in cold water). If blanching with a steamer or microwave, observe the relevant instructions).
- Do not salt or season food and blanched vegetables before freezing. Only lightly salt and season other foods. The intensity of flavour of certain seasonings changes.
- Do not freeze bottles and tins containing carbonated beverages, as otherwise they may burst.
- **For storage:** The individual storage tray can support max. 25 kg of frozen goods.
- **VarioSpace***: By removing the 2nd and 3rd drawer and the storage tray, you obtain the storage space for bulky goods equivalent to two drawer heights. Poultry, meat, large game pieces and tall baked goods can be frozen whole and further prepared in one piece.
- If you wish to use the max. holding capacity, you can remove the drawers and store the frozen goods directly on the storage trays .
 - **Removing drawers**, fig. G1: pull out to stop position and lift up at front.
 - **Removing storage tray**, fig. G2: remove 2nd and 3rd drawer, lift storage tray up at front and pull out.
To insert: simply push storage tray in, snap into position at front.



- **For defrosting**, always only remove as much as will be needed immediately. Defrosted food should be used to prepare a meal as soon as possible.
You can defrost frozen food:
 - in the oven/fan-assisted oven
 - in the microwave
 - at room temperature
 - Defrosted flat meat and fish portions can be heated up.
 - Vegetables can be prepared in a frozen state (at half cooking time as fresh vegetables).

6 Defrosting

Defrosting

The refrigerator compartment

defrosts automatically. The defrost water is evaporated by the heat from the compressor; drops of water on the rear wall are perfectly normal.

- Ensure that the defrost water can flow freely through the drain hole in the rear wall (arrow in fig. A).

The freezer compartment

- To defrost, switch off the appliance:
 - Disconnect the appliance from the mains .
- If possible, put the frozen goods in the freezer drawer, wrap in newspaper or a blanket and store in a cool place.
- To speed up the defrosting process place a saucepan of hot but not boiling water on one of the middle shelves.
Do not use electric heaters or steam cleaners, defrosting sprays or naked flames for defrosting nor any metal objects for removing the ice. Risk of injury and damage!
- Leave the appliance door open when defrosting. After defrosting, mop up the remaining water with a sponge or cloth and clean the appliance.

6 Cleaning

Cleaning

- **Before cleaning, always switch off the appliance. Disconnect from the mains or un-screw or switch off the fuse.**
- Wash shelves, glass plates and other options by hand.
- Clean the outer walls, inside and equipment by hand with lukewarm water and a little detergent. Because of the risk of injury and damage to the appliance, steam cleaning equipment should not be used.
- Do not use abrasive sponges or scourers, do not use concentrated cleaning agents and never use cleaning agents containing sand, chloride or acid or chemical solvents, as these would damage the surfaces and could cause corrosion.
- We recommend using a soft cloth and an all-purpose cleaner with a neutral pH value. Only use food safe cleaning materials inside the appliance.
- **For stainless-steel appliances*:**
 - Clean the side panels and door surfaces with a clean and soft cloth. If necessary, use a moist cloth (water + detergent). Alternatively, use a micro-fibre cloth.
- Ensure that no cleaning water penetrates into the electrical components, drain gully* or ventilation grilles. Wipe the appliance dry.
- Do not damage or remove the type plate on the inside of the appliance. It is very important for servicing purposes.
- Clean the **drain hole** on the rear wall above the vegetable bins frequently, fig. A, arrow. **If necessary, clean with a thin object, e.g. a cotton swab or similar.**
- Ensure that none of the wires or other components are dislodged, bent or damaged.
- Then connect/switch on the appliance.

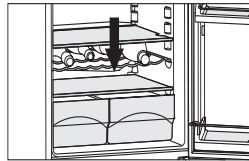

If the appliance is to be **left switched off for any length of time**, empty the appliance, disconnect from the mains, clean as described above and leave the door open so as to avoid odours.



7 Troubleshooting

Your appliance is designed and manufactured in such a way as to provide fault-free operation and a long service life. Nevertheless, if a fault should occur during operation, please check whether the fault is due to incorrect operation. In this case we have to charge you for any costs incurred also within the warranty period.

You can eliminate the following faults yourself by checking the possible causes:

Fault possible cause and remedy

Appliance not working, display is unlit

- Is the appliance switched on properly?
- Is the mains plug properly inserted in the socket?
- Is the socket fuse intact?

The interior light does not come on

- Is the refrigerator compartment switched on?
- Was the door open for longer than 15 min.?
- The bulb is defective. Change the bulb as described in "Interior light".

Loud running noise

- Is the appliance standing firmly on the floor, or does the compressor cause nearby items of furniture or objects to vibrate?

If necessary, move the appliance slightly, align by adjusting the adjustable feet, or move bottles and containers apart.

- The following are normal:

Flow noises, bubbling or dripping, coming from the coolant in the refrigerating circuit.

A soft *clicking sound*, this always occurs when the refrigeration unit (the motor) switches on or off automatically.

Motor noise; this will be slightly louder for a brief period when the refrigeration unit switches on. When SuperFrost is switched on, fresh food is inserted, or when the door is open for a long time, the refrigerating capacity increases automatically.

The compressor will continue to run for a while

- On energy saving models, this is caused by the functions and is perfectly normal. When less refrigeration is required, the VCC compressor switches to a low speed. It will then be running almost constantly, but it does save energy.

The inverter regularly flashes every 15 seconds*.

- The inverter is equipped with a diagnostic LED.
- The flashing is normal.

Customer service and type plate

If none of the above causes applies and you cannot eliminate the fault yourself or if *more than one LED is flashing*, please contact your nearest after-sales service point (see list attached).

Please state the **appliance designation** ①, **service number** ②, **appliance number** ③ of the rating plate (see fig.), and **which LED displays** are flashing so as to ensure rapid, accurate servicing. The rating plate is located inside the appliance on the left-hand side.

Keep the appliance closed until the after-sales service technician arrives in order to prevent further loss of refrigeration.

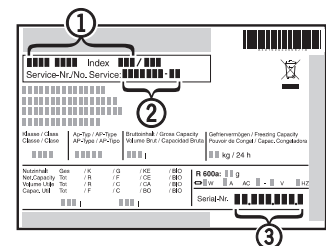

8 Instructions for installation and modification

Before reading, please fold out and refer to the illustrated back page.



The **external dimensions** of the appliance can be seen on fig. S.

Do not install the appliance side-by-side with another refrigerator or freezer. This is important to prevent condensation and consequential damage from it.

Changing over the door hinges

You can change over the door hinges if necessary.

Ensure that the following tools are to hand:

- Torx® 25
- Torx® 15
- Screwdriver
- Cordless screwdriver, if necessary
- Second person for fitting work, if needed
- Accompanying Allen key size 2

Detaching the upper door

- Close the upper door.
- Pull off the cover Fig. 1 (1) forwards and upwards.
- Lift off the cover Fig. 1 (2).

CAUTION

Risk of injury if the door tips!

- Take good hold of the door.
- Set down the door carefully.

- Unscrew the upper turn hinge Fig. 1 (3) (2x Torx® 25) Fig. 1 (4) and lift it off.
- Lift up the upper door and set it aside.

Detaching the lower door

- Close the lower door.
- Draw the middle bearing pin Fig. 2 (11) out of the turn hinge and lower door.
- Remove the plastic cap Fig. 2 (10).

CAUTION

Risk of injury if the door tips!

- Take good hold of the door.
- Set down the door carefully.

- Open the lower door.
- Unscrew the middle turn hinge (2x Torx® 25). Fig. 2 (13)
- Lift up the door and set it aside.

Transferring the middle bearing elements

- Carefully detach the cover panel Fig. 2 (12).
- Turn the middle turn hinge Fig. 2 (13) with the washer Fig. 2 (14) through 180° and screw it firmly into place on the new hinge side (with 4 Nm).
- Turn the cover panel Fig. 2 (12) through 180° and snap it into place again on the new handle side.

Transferring the lower bearing elements For appliances without height adjustment

- Lift out the bearing pin Fig. 3 (22) together with washer Fig. 3 (23) and foot Fig. 3 (24).
- Lift off the stopper Fig. 3 (21).
- Unscrew Fig. 3 (26) the turn hinge Fig. 3 (25).
- Unscrew Fig. 3 (29) the bearing element Fig. 3 (28), transfer it to the opposite location hole of the turn hinge and screw it firmly into place.
- Carefully lift off the cover on the handle side Fig. 3 (27) and transfer it to the opposite side.
- Screw the turn hinge Fig. 3 (25) firmly into place on the new hinge side, possibly using a cordless screwdriver (with 4 Nm).
- Re-insert the stopper Fig. 3 (21) into the other hole.
- Re-insert the bearing pin Fig. 3 (22) together with washer and foot. In so doing, pay attention that the locating lug points backwards.

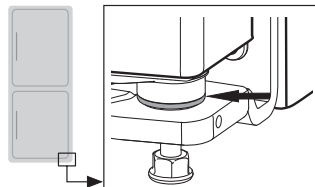

Transferring the handles

On both the upper and lower door:

- Transfer the spring clamp Fig. 5 (31): Depress the latch nose and pull the spring clamp off over it.
- Slide the spring clamp into place on the new hinge side until it clicks into place.
- Lift the stopper Fig. 6 (30) out of the door bearing bush and transfer it.
- Detach door handle Fig. 6 (32), stopper Fig. 6 (33) and pressure plates Fig. 6 (34) and transfer to the opposite side.
- When fitting the pressure plates on the opposite side, make sure they snap properly into place*.

Fitting the lower door

- Place the lower door from above onto the lower bearing pin.
- Close the door.
- Place the plastic cap Fig. 2 (10) back onto the middle turn hinge Fig. 2 (13).
- Place the middle bearing pin Fig. 2 (11) in the lower door, on the new hinge side, through the middle turn hinge Fig. 2 (13).

Fitting the upper door

- Place the upper door on the middle bearing pin Fig. 2 (11).
- Insert the upper turn hinge Fig. 1 (3) in the door on the new hinge side.
- Screw the upper turn hinge firmly into place (with 4 Nm) (2x Torx® 25) Fig. 1 (4). Possibly make preliminary holes with a bradawl or use a cordless screwdriver.
- Apply the cover Fig. 1 (1) and cover Fig. 1 (2) to the opposite side from the outside and snap them into place.

Aligning the doors

- If necessary, align the doors to the appliance housing by way of the two oblong holes in the bottom turn hinge and middle turn hinge Fig. 2 (13). To do so, unscrew the middle screw in the bottom turn hinge.

WARNING

Risk of injury due to the door dropping out!

If the bearing parts are not screwed into place firmly enough, the door may drop out. This may lead to severe injuries.

What is more, the door may not close and therefore the appliance may fail to cool properly.

- Screw the turn hinges firmly into place with 4 Nm.
- Check all of the screws and retighten if necessary.

Insertion into row of kitchen units

- ① top unit
- ② refrigerator/freezer
- ③ Kitchen cupboard
- ④ wall

Fig. U: The appliances can be installed in a row of kitchen units. To adapt the height of the appliance to the surrounding furniture a top unit ① can be added.

When retrofitting with standard kitchen cabinets (max. depth 580 mm), the appliance can be set up directly next to the kitchen cupboard Fig. U ③. The appliance door protrudes 34 mm at the side and 50 mm in the middle of the appliance against the front panel of the kitchen cupboard. It can therefore be opened and closed without any problems.

Important for ventilation:

- On the rear side of the top unit there must be a ventilation duct of at least 50 mm depth along the entire width of the top unit.
- The area of ventilation underneath the ceiling must be at least 300 cm².
- The larger the ventilation cross section, the more energy the appliance will be able to save.

If the appliance is installed with the hinge side against a wall Fig. U ④, the distance between the appliance and the wall must be at least 36 mm. This corresponds with the handle protrusion when the door is open.

All types and models are subject to continuous improvement and the manufacturer therefore reserves the right to make modifications in the shape, equipment and technology.

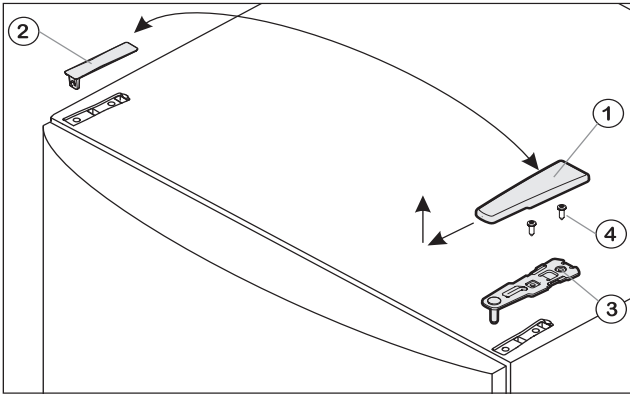

Fig.1

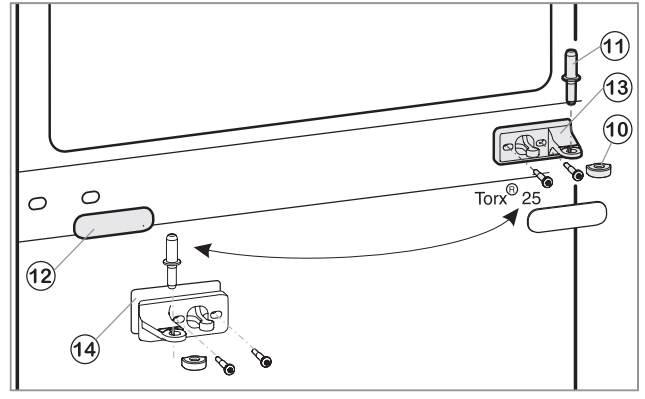

Fig.2

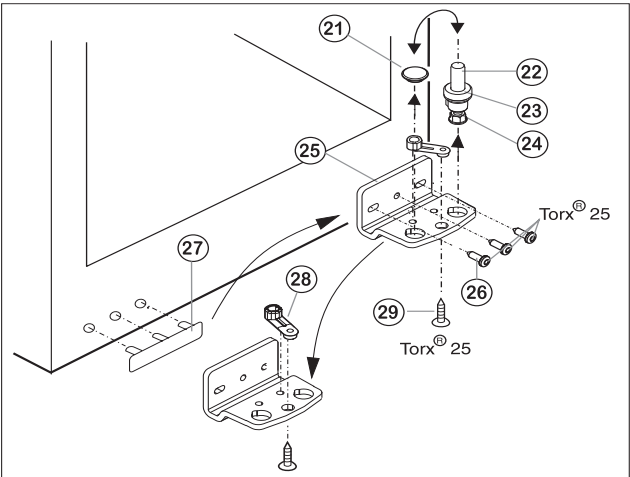

Fig.3

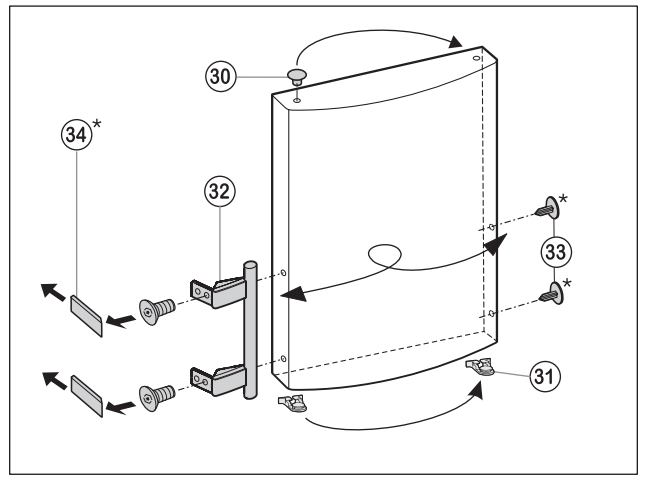

Fig.6

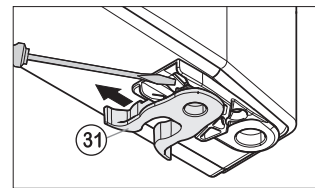

Fig.5

