

7082 547-01

CBN 5113 210

LIEBHERR

Disposal notes

- **Keep packaging materials away from children - polythene sheets and bags can cause suffocation!**
- Please return the packaging to an official collection point.

Your old appliance: This contains some reusable materials and should be disposed of properly - not simply with unsorted household refuse.

- Discarded appliances should be disabled: Remove the plug, cut through the connection cable and render the catch unusable so that children cannot become trapped inside.
- Ensure that the refrigerant circuit is not damaged when the appliance that is no longer needed is taken away for disposal.
- Details of the refrigerant can be found on the type plate.
- Appliances which are no longer needed must be disposed of in a professional and appropriate way, in accordance with the current local regulations and laws.



Range of appliance use

The appliance is suited only for cooling food. In the case of commercial food cooling, the pertinent statutory regulations have to be observed.

The appliance is not suited for storing and cooling pharmaceuticals, blood plasma, laboratory preparations or similar substances and products subject to the Medical Devices Directive 2007/47/EC.

Any misuse of the appliance may result in damage to or spoilage of the stored goods.

Furthermore, the appliance is unsuited for use in areas exposed to an explosion hazard.

Description of appliance and equipment

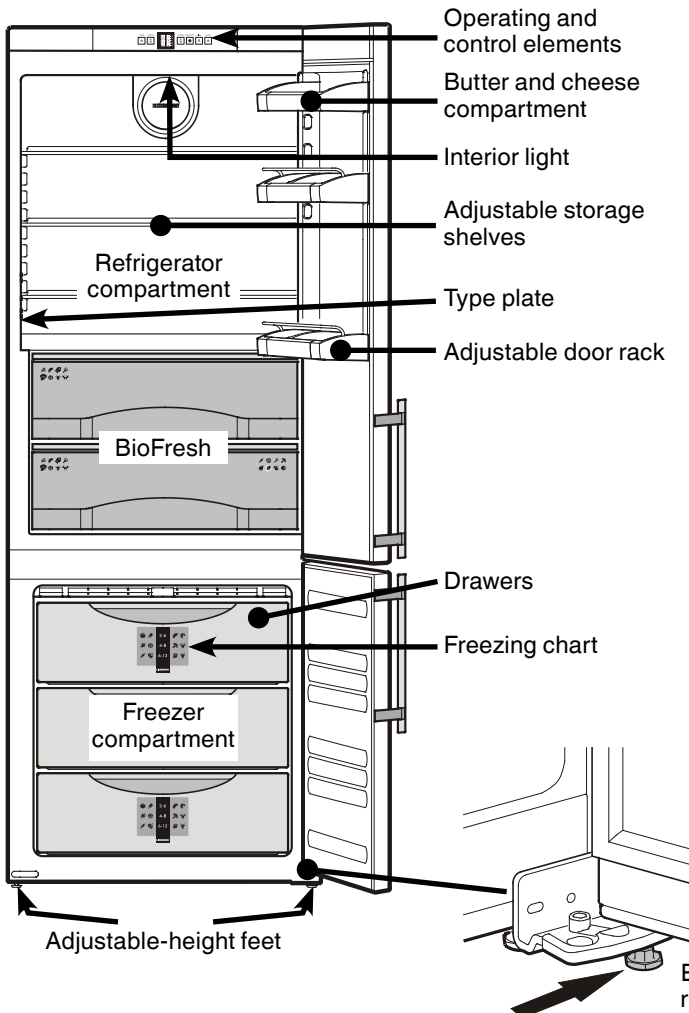

Safety instructions and warnings

- To prevent injury or damage to the unit, the appliance should be unpacked and set up by two people.
- In the event that the appliance is damaged on delivery, contact the supplier immediately before connecting to the mains.
- To guarantee safe operation, ensure that the appliance is set up and connected as described in these operating instructions.
- Disconnect the appliance from the mains if any fault occurs. Pull out the plug, switch off or remove the fuse.
- When disconnecting the appliance, pull on the plug, not on the cable.
- Any repairs and work on the appliance should only be carried out by the customer service department, as unauthorised work could prove highly dangerous for the user. The same applies to changing the mains power cable.
- Do not allow naked flames or ignition sources to enter the appliance. When transporting and cleaning the appliance ensure that the refrigerant circuit is not damaged. In the event of damage, make sure that there are no ignition sources nearby and keep the room well ventilated.
- Do not stand on the plinth, drawers or doors or use them to support anything else.
- This appliance is not intended for use by persons (including children) with reduced physical, sensory or mental capabilities or lack of experience and knowledge unless they have been given initial supervision or instruction concerning use of the appliance by a person responsible for their safety. Children should be supervised to ensure that they do not play with the appliance.
- Avoid prolonged skin contact with cold surfaces or chilled/frozen food. This could cause pain, numbness and frostbite. In the case of prolonged skin contact, protective measures should be taken, e.g. gloves should be worn.
- Do not eat ice cream, particularly ice lollies or ice cubes, immediately after taking them from the freezer compartment as there is a risk of "burning" because of the very cold temperatures.
- Do not consume food which has been stored for too long, as it could cause food poisoning.
- The appliance is designed for cooling, freezing and storage of food, and for making ice and is intended for domestic use. If used for commercial purposes, the relevant legal regulations applicable to the trade concerned must be observed.
- Do not store explosives or sprays using combustible propellants such as butane, propane, pentane etc. in the appliance. Electrical components might cause leaking gas to ignite. You may identify such sprays by the printed contents or a flame symbol.
- Do not use electrical appliances inside the appliance.
- The appliance is designed for use in enclosed areas. Do not operate the appliance outdoors or in areas where it is exposed to splash water or damp conditions.
- Special-purpose lamps (incandescent lamps, LEDs, fluorescent tubes) in the appliance serve to illuminate the appliance interior and are not suited for room illumination.

Climate rating

The appliance is set to operate within specific ambient temperature limits according to its climate rating. These temperature limits should not be exceeded. The correct climate rating for your appliance is indicated on the type plate.

Climate rating	Ambient temperature
SN	+10°C to +32°C
N	+16°C to +32°C
ST	+16°C to +38°C
T	+16°C to +43°C

Setting up

- Avoid positioning the appliance in direct sunlight or near cookers, radiators and similar sources of heat.
- The floor on which the appliance stands should be horizontal and level. To compensate for any unevenness, adjust the height of the feet with the open-ended spanner supplied.
- The ventilation grilles should not be obstructed. Always ensure that there is good ventilation and that the outward flowing air is able to escape.
- Do not place heat-emitting appliances, e.g. microwave oven, toaster, etc., on top of the appliance.
- Standard EN 378 specifies that the room in which you install your appliance must have a volume of 1 m³ per 8 g of R 600a refrigerant used in the appliance, so as to avoid the formation of inflammable gas/air mixtures in the room where the appliance is located in the event of a leak in the refrigerant circuit. The quantity of refrigerant used in your appliance is indicated on the type plate on the inside of the appliance.
- Do not connect the appliance to the supply with other equipment using an extension cable - risk of overheating.

Dimensions (mm)

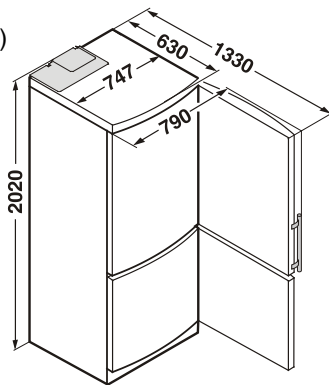

Connecting to the mains

Power supply (AC) and voltage at the operating point must comply with the details on the type plate, which is located inside the appliance on the left-hand side. The socket must be fused with a 10 A fuse or higher, it must be away from the rear of the appliance and must be easily accessible.

Connect the appliance with a properly earthed fused plug and socket only.

Saving energy

- Always ensure good ventilation. Do not cover ventilation openings or grille.
- Always keep fan louvres clear.
- Do not place appliance in areas of direct sunlight or next to a stove, heater or similar object.
- The energy consumption depends on the installation conditions, e.g. the ambient temperature.
- Keep the time the appliance is open to a minimum.
- Store food logically.
- Ensure that all food is well packed and covered for storage. This will prevent frost from forming.
- First cool warm food to room temperature before storing it.
- Defrost frozen food in the refrigerator.
- If there is a thick layer of frost in the appliance: defrost the appliance.
- Empty and switch off refrigerating unit for longer vacation periods.

Accumulated dust increases the energy consumption:

- Once a year, dust the refrigerating unit together with the metal grille of the heat exchanger at the back of the appliance.

Operating and control elements

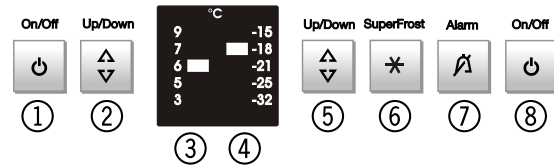

Refrigerator

- ① On/Off button
- ② Temperature setting button
- ③ Temperature display

Freezer

- ④ Temperature display
- ⑤ Temperature setting button
- ⑥ SuperFrost button
- ⑦ Audible warning on/off button
- ⑧ On/Off button

Switching the appliance on and off

Clean the interior of the appliance before switching it on for the first time (see "Cleaning").

To switch on

Press the On/Off button ① to switch on the refrigerator compartment.

Press the On/Off button ⑧ to switch on the freezer compartment.

To switch off

Press the On/Off buttons for approx. two seconds.

Setting the temperature

The temperature of the refrigerator and freezer compartment can be set separately.

Setting the refrigerator temperature:

Press the Up/Down button ②, the LED in the temperature display ③ for the next lower temperature value will light up. Keep pressing the Up/Down button ② until the desired value is displayed.

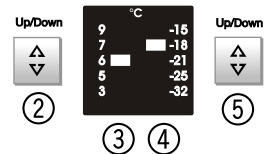

Setting the freezer temperature:

Press the Up/Down button ⑤ until the desired value is displayed in the temperature display ④.

Note

Long pressing of the setting button sets a slightly colder value within a small temperature range (e.g.: between "7" and "9"), but it is not visible in the display.

Audible warning on/off button

The appliance is equipped with an alarm function.

Audible door alarm

If an appliance door is left open for more than 60 seconds, the audible warning signal will sound. Press the audible warning on/off button to cancel the alarm. The alarm switches back to standby when the door is shut.

Alarm



⑦

Audible/visual temperature alarm

If the temperature in the freezer compartment rises too high, the audible warning signal will sound and the LED in the audible warning on/off button will flash.

Press the audible warning on/off button to cancel the alarm. The LED will stop flashing and will light continuously. The LED will go out as soon as the temperature in the freezer compartment is low enough.

This can be caused by:

- the freezer door being left open for a long time, allowing warm ambient air to enter;
- a long power failure;
- a fault in the appliance.

In each case, make sure food has not thawed or perished. If the visual warning LED does not go out, contact the customer service department (see section on "Malfunctions").

Equipment

You can re-arrange the **storage shelves** as required.

Lift the glass shelf, align the recess over the support and replace the shelf in a higher or lower position.

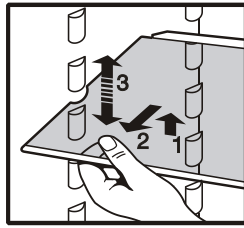

Repositioning the door racks

- Lift door rack vertically (1), lift out to the front and re-insert at a different height, following these steps in the reverse order (2).

- By shifting the **bottle holder F** you can protect the bottles from falling over when opening or closing the door.

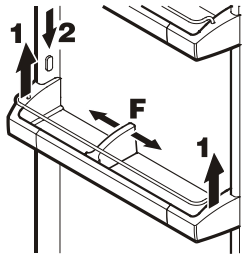

Place the shelf rails provided, fig. 1, on the supports on the left and right at the desired height.

Insert the glass shelves (1) and (2) as shown in fig. 2. The glass shelf (2) with the raised edge must go at the back.

If you need to make space for tall containers, simply slide the **front half** of the sectioned glass shelf carefully underneath the back half, fig. 2.

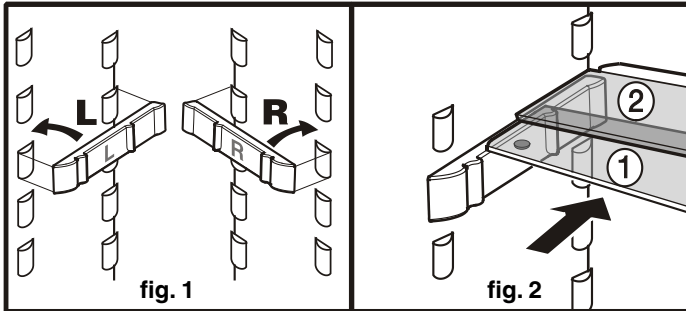

Cooling

Storage example

- ① butter, cheese
- ② eggs, cans, tubes
- ③ bottles
- ④ frozen food, ice cubes
- ⑤ meat, sausage products, dairy products
- ⑥ meat, sausage products, fish, dairy products, salad, fruit, vegetables

Note

- Food which gives off or absorbs odours and flavours as well as liquids should always be stored covered or in closed containers. High-percentage alcohols should be tightly sealed and stored upright.
- Reusable plastic, metal, aluminium and glass containers can be used for packaging.
- Allow hot food to cool to room temperature before storing it in the appliance.

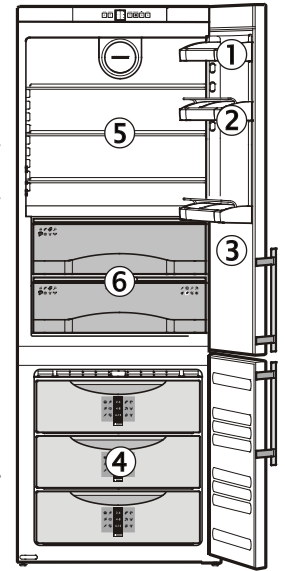

Interior light

Bulb data: 25 W (never use a bulb rated at more than 25 W). The voltage should agree with the details on the type plate.
Socket: E 14.

Replacing the bulb:

Pull out the mains plug or remove/unscrew the fuse.

- To remove the cover (1): put your finger behind the cover and disengage it.
- Pull out the glass plate (2).
- Change the bulb (3).
- Slide the glass plate back in.
- Attach the cover again: engage it at the right and left and pay attention that the middle hook (4) grips over the glass plate.

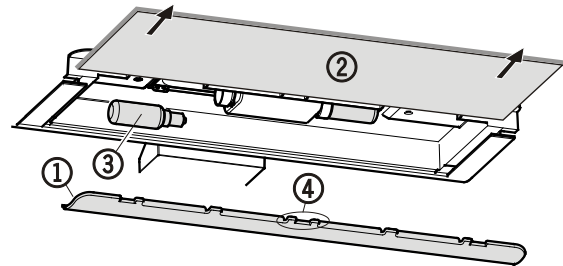

BioFresh compartment

The BioFresh compartment enables you to keep food for up to 3 times longer than in normal refrigerators.

The constant temperature of just above 0°C and the adjustable humidity provide the ideal storage conditions for different types of food.

Humidity selection:

- **dry:** small humidity symbol - slide control to left. This setting is suitable for dry or wrapped food like dairy products, meat, fish, cold meats.
- **moist:** high relative humidity of max. 90%, large humidity symbol - slide control to right. This setting is suitable for storing unwrapped food with a high moisture content such as salad, vegetables and fruit.

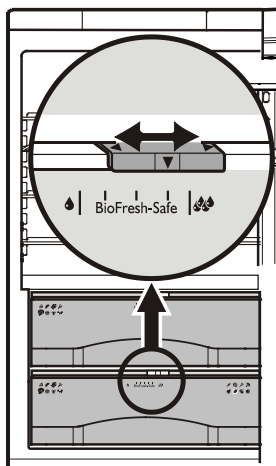

Notes

- The humidity in the compartment depends on the moisture content of the food in it, and the frequency with which the compartment is opened.
- The fresher the product and the higher its quality, the longer it will keep.
- Unwrapped animal and vegetable foods should be stored separately in the drawers. If there is not enough space for them to be stored separately, make sure that they are wrapped. Do not allow different types of meat to come into contact with one another but keep them packaged separately so as to avoid premature bacterial spoilage.
- The following products should not be stored in the BioFresh compartment: hard cheese, potatoes, cold-sensitive vegetables such as cucumber, aubergines, avocados, semi-ripe tomatoes, zucchini, and all cold-sensitive tropical fruits such as pineapple, bananas, grapefruit, melons, mangoes, papaya, etc.

Adjusting the temperature in the BioFresh compartment

The temperature is controlled automatically between 0°C and 3°C, the recommended temperature is 1°C. You can set the temperature slightly lower or higher.

The temperature can be adjusted from **1** (coldest temperature setting) to **9** (warmest temperature setting). The presetting is **5**. At the **1** to **4** settings the temperature may drop below 0°C and therefore the food may freeze slightly.

A combination of LEDs that corresponds to the value shines in the temperature display.

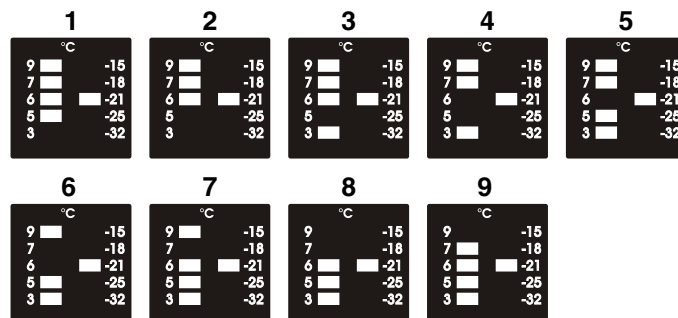

- To activate the setting mode: Press the SuperFrost button for at least 5 seconds. The SuperFrost button flashes. The LEDs of the set value shine in the temperature display.
- Press the setting button, freezer compartment the number of times needed until the LEDs of the value wanted shine.
- To confirm: Press the SuperFrost button. The temperature is indicated again in the temperature display.
- To deactivate the setting mode: press On/Off button, freezer compartment.

Freezing

The maximum amount of food (in kg) which can be frozen in 24 hours is shown on the type plate ("Freezing capacity").

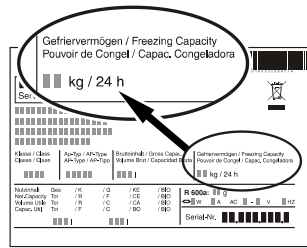

SuperFrost

By activating the SuperFrost function the temperature in the freezer compartment will drop to the lowest attainable value. Thus food can be rapidly frozen to the core and the quality is preserved.

- Press the SuperFrost button (6). The SuperFrost lamp comes on.
- Wait 24 hours.
- Place the fresh food in the freezer.
- The automatic SuperFrost system automatically switches the fast freezing procedure off after 65 hours.

You should not switch on the SuperFrost function:

- when placing frozen food in the freezer;
- when freezing up to approx. 2 kg fresh food daily.

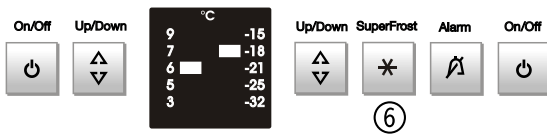

Making ice cubes

- Fill the ice-cube tray with water.
- Place the ice-cube tray in the appliance and leave it to freeze.
- The ice cubes can be removed from the tray by twisting or by holding upside down for a short time under running water.

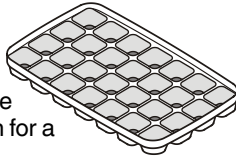

Notes on freezing

- Pack food which you are freezing yourself in quantities appropriate to your household. To ensure that the food freezes right through, the following quantities should not be exceeded per package: fruit, vegetables: up to 1 kg, meat: up to 2.5 kg.
- Do not allow fresh food which is to be frozen to come into contact with food already frozen. Always keep packs dry in order to avoid them sticking together.
- Always write the date and contents on the pack and do not exceed the stated storage time for the food.
- Do not freeze bottles and cans which contain carbonated drinks as they might burst.
- Only take out as much food as is immediately required for thawing. Use food which has been thawed in prepared meals as quickly as possible.

Frozen food can be thawed in the following ways: in a fan oven, in a microwave oven, at room temperature, in the refrigerator.

Freezing chart

The freezing chart represents the frozen food and the time it can be safely stored in months. The individual storage times and whether or not the lower or upper value is applicable depend on the food quality, its processing prior to freezing, and the individual household's quality requirements. The lower values always apply to food with a high fat content.

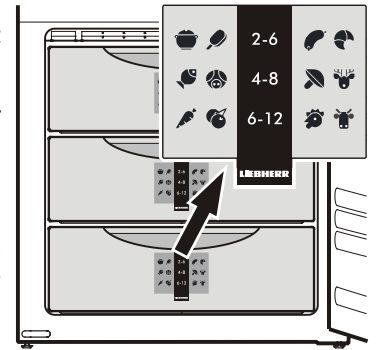

Cold-storage accumulators

The cold-storage accumulators provided prevent the temperature in the freezer from rising too quickly in the event of a power failure, thus preserving the quality of the food.

To ensure maximum storage time in the event of a power failure, place the cold-storage accumulators in the top-most freezer drawer on top of the food.

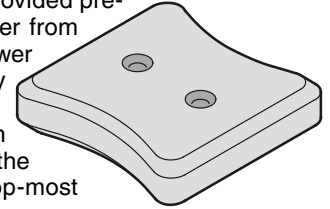

Defrosting

Refrigerator compartment

The refrigerator compartment defrosts automatically. The water that forms on the rear wall drains into a reservoir at the back of the appliance and evaporates automatically through the compressor heat.

Freezer compartment

The No-frost system automatically defrosts the appliance.

Any moisture arising collects on the evaporator and freezes, and is periodically defrosted and evaporated.

Cleaning

Before cleaning always switch off the appliance. Pull out the mains plug or remove/unscrew the fuse.

- Clean the side panels and door surfaces with a clean and soft cloth. If necessary, use a moist cloth (water + detergent). Alternatively, use a micro-fibre cloth.
- Do not use abrasive sponges or scourers, do not use concentrated cleaning agents and never use cleaning agents containing sand, chloride or acid or chemical solvents, as these would damage the surfaces and could cause corrosion.
- Clean the inside and equipment parts with lukewarm water and a little detergent.

Do not use steam cleaners because of the risk of injury and damage.

- Ensure that no cleaning water penetrates into the electrical components or ventilation grille.
- Dry all parts well with a cloth.
- Clean the drain hole in the refrigerator compartment with a thin object, e.g. cotton swab or the like.
- Do not damage or remove the type plate on the inside of the appliance. It is very important for servicing purposes.

Shutting your appliance down

If your appliance is to be shut down for any length of time, switch it off and disconnect the plug or switch off or unscrew the fuse. Clean the appliance and leave the door open in order to prevent unpleasant smells.

The appliance complies with the relevant safety regulations and EC Directives 2004/108/EC and 2006/95/EC.

All types and models are subject to continuous improvement and the manufacturer therefore reserves the right to make modifications to the shape, equipment and technology.

Malfunctions

You may be able to rectify the following faults by checking the possible causes yourself:

- **Appliance does not function:**
 - Is the appliance switched on?
 - Is the plug correctly fitted in the mains socket?
 - Is the socket fuse intact?
- **Loud running noise:**
 - Is the appliance set up firmly on the floor?
 - Does the appliance cause nearby items of furniture or objects to vibrate? Please note that noises caused by the refrigerant circuit cannot be avoided.
- **The temperature is not low enough:**
 - Is the temperature setting correct (see "Setting the temperature")?
 - Have excessive amounts of fresh food been placed in the appliance?
 - Does the separately installed thermometer show the correct reading?
 - Is the ventilation system working properly?
 - Is the appliance set up too close to a heat source?

If none of the above causes apply and you cannot rectify the fault yourself, contact the nearest customer service department stating the type designation ①, service number ② and appliance number ③ as indicated on the type plate. The type plate is located inside the appliance on the left-hand side.

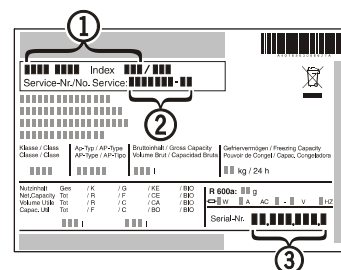

Installing appliance in a row of kitchen units

To adapt the height of the appliance to the surrounding furniture a top unit ① can be added.

A gap of at least 50 mm depth must be provided behind and along the entire width of this unit so as to ensure sufficient ventilation. The area of ventilation underneath the ceiling should be at least 300 cm².

When setting up the appliance next to a wall ④, a distance of approx. 50 mm must be provided on the hinge side between the appliance and the wall (for the handle when the door is open).

- ① top unit
- ② refrigerator-freezer
- ③ kitchen unit side panel
- ④ wall

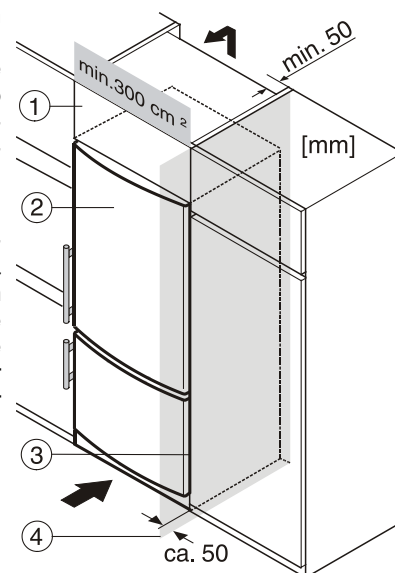

Changing over door hinges

Door hinges should only be changed by a trained expert.

Changing the door hinges must be done by two people.

1. Remove cover.
2. Unscrew hinge bracket.
3. Remove top door.

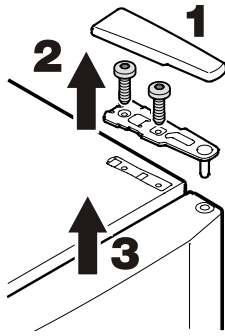

4. Transfer cover plate to the opposite side.

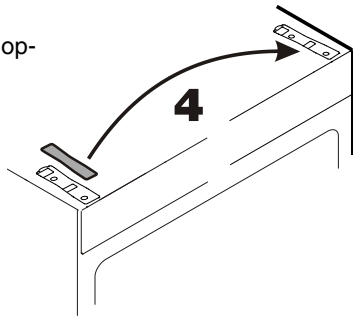

5. Pull out middle hinge pin.
6. Remove bottom door.

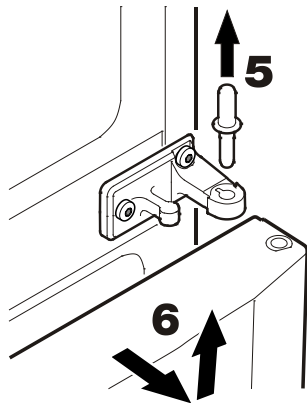

7. Transfer plug.
8. Lever out pressure plates at the front and slide away.
9. Transfer door handles and plugs to the other side.
10. Transfer spring clip to the opposite side.

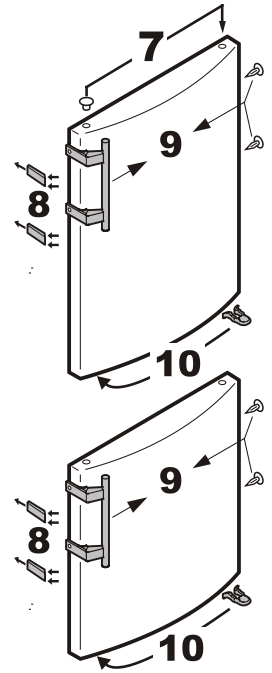

11. Unscrew hinge bracket.
12. Transfer cover plate to the opposite side.
13. Turn hinge bracket through 180° and screw into place.

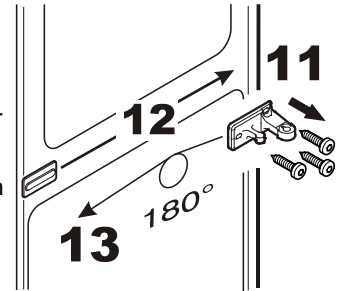

14. Remove hinge bushing, turn through 180° and re-fit.

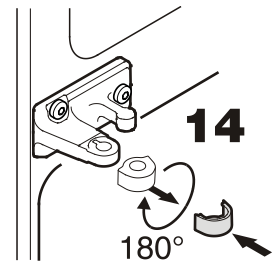

15. Remove cover.
16. Remove spacer.
17. Tilt appliance slightly backwards and pull out hinge pin.
18. Unscrew hinge bracket.

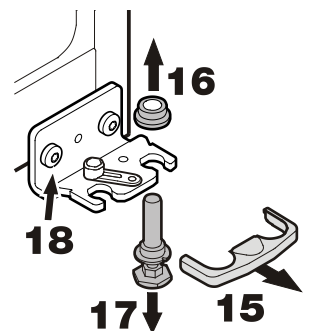

19. Transfer the hinge component on the hinge bracket to the opposite side.

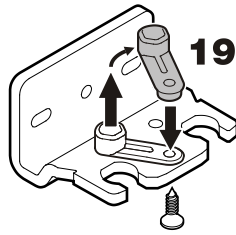

25. Insert middle hinge pin.

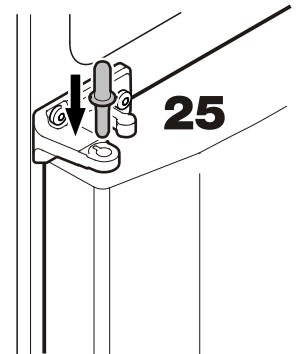

20. Transfer cover plate to the opposite side.

21. Screw hinge bracket into place.

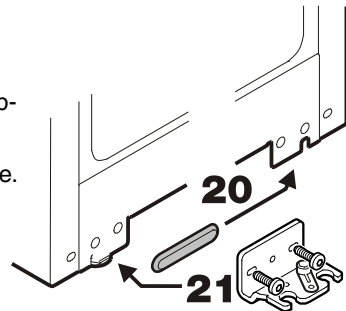

26. Suspend top door on hinge pin and close.

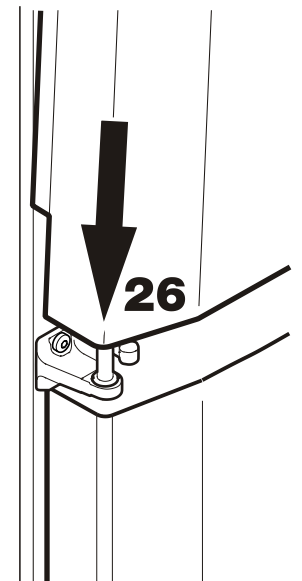

22. Tilt appliance slightly backwards, insert hinge pin and fit spacer.

23. Click cover into place.

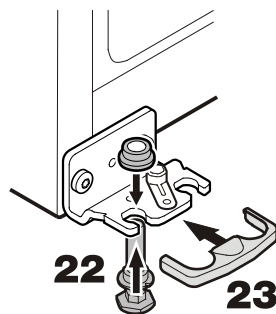

27. Insert hinge bracket and screw into place.

28. Click cover into place.

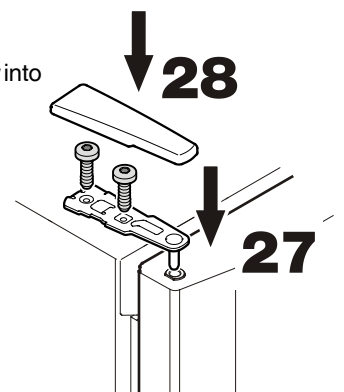

24. Suspend bottom door on hinge pin and close.

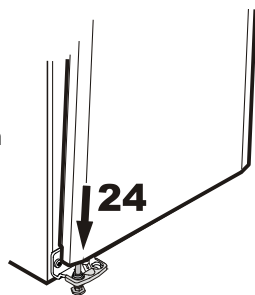

If necessary, align the doors to the appliance housing using the two oblong holes in the bottom hinge and centre hinge.