

Operating and installation instructions

Upright refrigerator with BioFresh compartment

GB

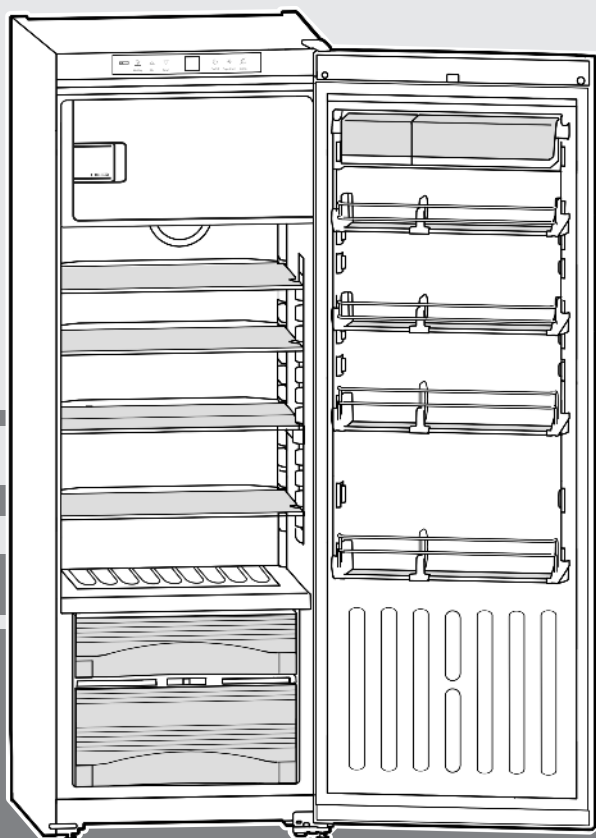

150710 **7084566 - 00**

KBgw/KBgb ... 6

LIEBHERR

Appliance at a glance

Contents

1	Appliance at a glance	2
1.1	Description of appliance and equipment.....	2
1.2	Range of appliance use.....	2
1.3	Conformity.....	3
1.4	External dimensions of the appliance.....	3
1.5	Saving energy.....	3
1.6	HomeDialog.....	3
2	General safety information	3
3	Controls and displays	4
3.1	Operating and control elements.....	4
3.2	Temperature display.....	4
4	Putting into operation	4
4.1	Changing over the door hinges.....	4
4.2	Insertion into a row of kitchen units.....	7
4.3	Transporting the appliance.....	7
4.4	Installing the appliance.....	7
4.5	Disposing of packaging.....	8
4.6	Connecting the appliance.....	8
4.7	Switching on the appliance.....	8
5	Control	9
5.1	Brightness of the temperature display.....	9
5.2	Child proofing.....	9
5.3	Door alarm.....	9
5.4	Refrigerator compartment.....	9
5.5	BioFresh compartment.....	10
5.6	Freezer compartment.....	12
6	Maintenance	12
6.1	Defrosting.....	12
6.2	Cleaning the appliance.....	13
6.3	Customer service.....	13
7	Malfunction	13
8	Decommissioning	14
8.1	Switching off the appliance.....	14
8.2	Taking the appliance out of service.....	14
9	Disposing of the appliance	14

The manufacturer works constantly on the further development of all the types and models. Therefore please understand that we have to reserve the right to make design, equipment and technical modifications.

To get to know all the benefits of your new appliance, please read the information contained in these instructions carefully.

The instructions apply to several models. Differences may occur. Text relating only to specific appliances is marked with an asterisk (*).

Instructions for action are marked with a ►, the results of action are marked with a ▷.

1 Appliance at a glance

1.1 Description of appliance and equipment

Note

- Place food inside the appliance as shown in the diagram. This allows the appliance to save energy during operation.
- Shelves, drawers and baskets are arranged for optimum energy efficiency on delivery.

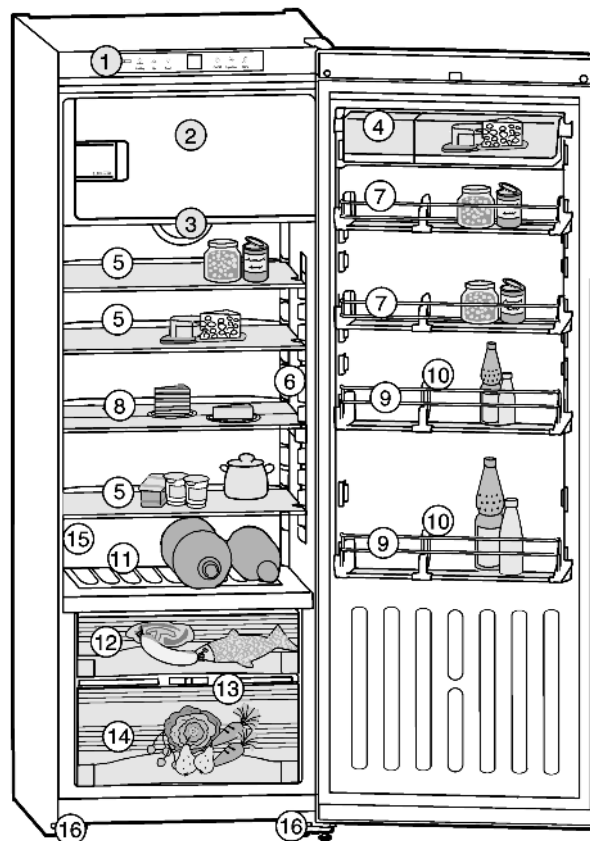

Fig. 1

- | | |
|---|--------------------------------------|
| (1) Operating and control elements | (9) Bottle rack |
| (2) Freezer compartment | (10) Bottle holder |
| (3) Fan | (11) Bottle shelf |
| (4) Box shelves, removable | (12) BioFresh compartment, Drysafe |
| (5) Glass shelves, relocatable | (13) HydroSafe control |
| (6) Interior light, LED | (14) BioFresh compartment, Hydrosafe |
| (7) Rack for tinned food, relocatable | (15) Type plate |
| (8) Glass shelf, sectioned, relocatable | (16) Adjustable feet |

1.2 Range of appliance use

The appliance is suited only for cooling food.

In the case of commercial food cooling, the pertinent statutory regulations have to be observed. The appliance is not suited for storing and cooling pharmaceuticals, blood plasma, laboratory preparations or similar substances and products subject to the Medical Devices Directive 2007/47/EC. Any misuse of the appliance may result in damage to or spoilage of the stored goods. Furthermore, the appliance is unsuited for use in areas exposed to an explosion hazard.

The appliance is set to operate within specific ambient temperature limits according to its climate rating. The correct climate rating for your appliance is indicated on the type plate.

Note

- Compliance with the ambient temperatures indicated is required, otherwise the cooling performance is reduced.

Climate rating	for ambient temperatures of
SN	10 °C to 32 °C
N	16 °C to 32 °C

Climate rating	for ambient temperatures of
ST	16 °C to 38 °C
T	16 °C to 43 °C

1.3 Conformity

The refrigerant circuit has been tested for leaks. The appliance complies with current safety regulations and EC directives 2006/95/EC and 2004/108/EC.

1.4 External dimensions of the appliance

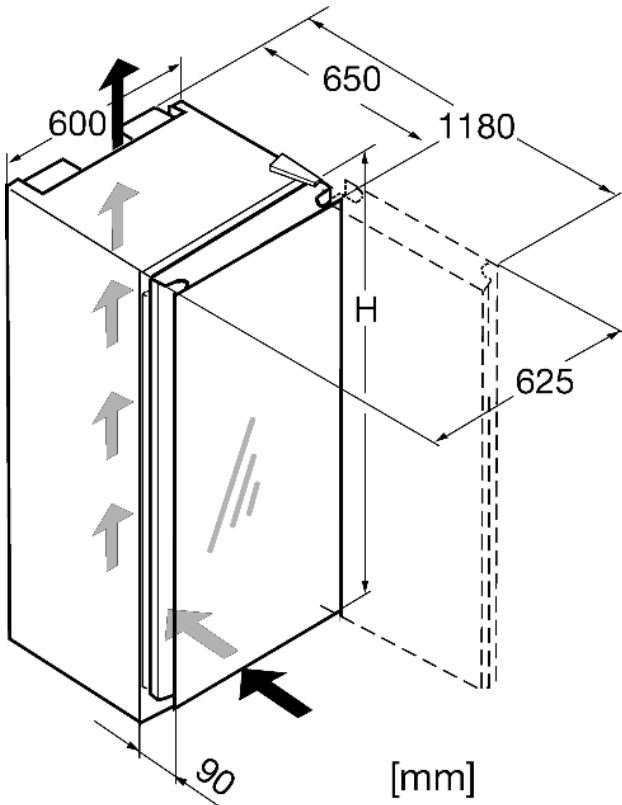

Fig. 2

Designation	H (mm)
KBg.. 38	1852

1.5 Saving energy

- Always ensure good ventilation. Do not cover ventilation openings or grille.
- Do not place appliance in areas of direct sunlight or next to a stove, heater or similar object.
- The energy consumption depends on the installation conditions, e.g. the ambient temperature (see 1.2).
- Keep the time the appliance is open to a minimum.
- Store food logically.
- Ensure that all food is well packed and covered for storage. This will prevent frost from forming.
- First cool warm food to room temperature before storing it.
- Defrost frozen food in the refrigerator.

Accumulated dust increases the energy consumption:

- Once a year, dust the refrigerating unit together with the metal grille of the heat exchanger at the back of the appliance.

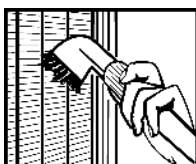

1.6 HomeDialog

Depending on model and options, the HomeDialog system can be used to network a number of Liebherr appliances (situated, for example, in the basement) with a main appliance (sited, for example, in the kitchen) and control them via the latter. You will find more information on the benefits, requirements and principle of operation on the internet at www.liebherr.com.



GB

2 General safety information

Danger for the user:

- This appliance is not designed for persons (including children) with physical, sensory or mental impairment or persons not having sufficient experience and knowledge, unless they are instructed in the use of the appliance and are initially supervised by a person responsible for their safety. Keep children under supervision to ensure they do not play with the appliance.
- In case of a fault, pull out the mains plug (not by pulling the connecting cable) or switch off the fuse.
- Have any repairs to or intervention in the appliance, and any change of the mains power cable, carried out by the customer service only or by other specialised personnel trained for the purpose.
- When disconnecting the appliance from the supply, always take hold of the plug. Do not pull the cable.
- Install and connect the appliance only as instructed.
- Please keep these instructions in a safe place and pass them on to any subsequent owners.
- Special-purpose lamps (incandescent lamps, LEDs, fluorescent tubes) in the appliance serve to illuminate the appliance interior and are not suited for room illumination.

Fire hazard:

- The refrigerant R 600a is environmentally friendly but flammable. Escaping refrigerant may ignite.
 - Do not damage the refrigerant circuit pipes.
 - Do not allow naked flames or ignition sources to enter the appliance.
 - Do not use any electrical appliances in the interior (e.g. steam cleaners, heaters, ice cream maker etc.).
 - If refrigerant escapes: eliminate naked flames or sources of ignition from the vicinity. Pull out the power plug. Ventilate the area well. Notify customer service.
- Do not store explosives or sprays using combustible propellants such as butane, propane, pentane, etc. in the appliance. Respective spray cans can be identified by reference to the contents printed on the can or by a flame symbol. Gases possibly escaping may ignite due to electrical components.
- Do not place any burning candles, lamps or other items with naked flames on or in the appliance.
- Only store high-percentage alcohol in tightly sealed, upright containers. Alcohol possibly escaping may ignite due to electrical components.

Danger of tipping and falling:

- Do not misuse the plinth, drawers, doors etc. as a step or for support. This applies particularly to children.

Danger of food poisoning:

- Do not consume food which has been stored too long.

Danger of frostbite, numbness and pain:

- Avoid lasting skin contact with cold surfaces or refrigerated/frozen food or take protective steps, e.g. wear gloves. Do not consume ice cream, water ice or ice cubes immediately and do not consume them too cold.

Risk of crushing

Controls and displays

- Do not reach into the soft stop mechanism. Fingers may be trapped when the door is closed.

Please observe the specific information in the other sections:

	DANGER	identifies a situation involving direct danger which, if not obviated, may result in death or severe bodily injury.
	WARNING	identifies a dangerous situation which, if not obviated, may result in death or severe bodily injury.
	CAUTION	identifies a dangerous situation which, if not obviated, may result in minor or medium bodily injury.
	NOTICE	identifies a dangerous situation which, if not obviated, may result in damage to property.

	Note	identifies useful information and tips.
--	------	---

3 Controls and displays

3.1 Operating and control elements

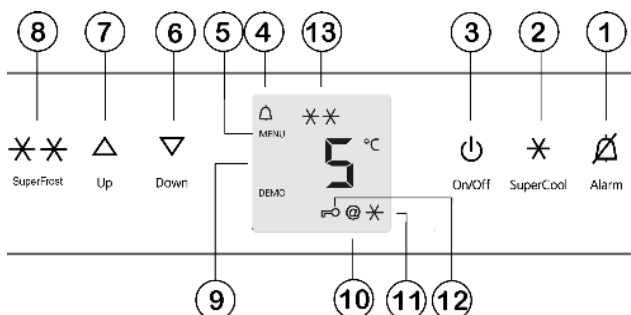

Fig. 3

- | | |
|-------------------------|----------------------------|
| (1) Alarm button | (8) SuperFrost button |
| (2) SuperCool button | (9) Temperature display |
| (3) On/Off button | (10) HomeDialog symbol |
| (4) Alarm symbol | (11) SuperCool symbol |
| (5) Menu symbol | (12) Child-proofing symbol |
| (6) Down setting button | (13) SuperFrost symbol |
| (7) Up setting button | |

3.2 Temperature display

The following are displayed in normal operation:

- the average cooling temperature

The following displays indicate malfunction. Possible causes and corrective action (see Malfunction).

- F8 to F9

4 Putting into operation

4.1 Changing over the door hinges

You can change over the door hinges if necessary.



WARNING

Risk of injury and damage due to pieces of broken glass!
The glass door is heavy. If it falls or there is impact on the glass edges, the glass pane may shatter.

- ▶ Protect the door properly when detaching it!
- ▶ Detach the glass door working in a team of two.
- ▶ Put the door down on a soft mat.

Ensure that the following tools are to hand:

- Torx 25
- Torx 15
- Screwdriver
- Cordless screwdriver, if necessary
- A soft mat

4.1.1 Detaching the upper soft stop mechanism

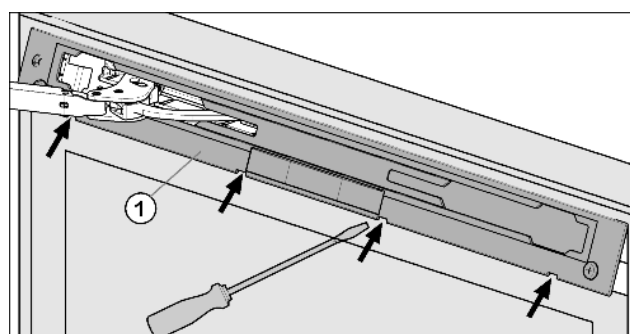

Fig. 4

- ▶ Open the upper door.

NOTICE

Risk of damage!

If the door seal is damaged, the door may fail to close properly and the cooling will be inadequate.

- ▶ Do not damage the door seal with the screwdriver!

- ▶ Disengage and remove the faceplate Fig. 4 (1) using a flat-blade screwdriver.
- ▶ The faceplate is attached over the soft stop bracket.

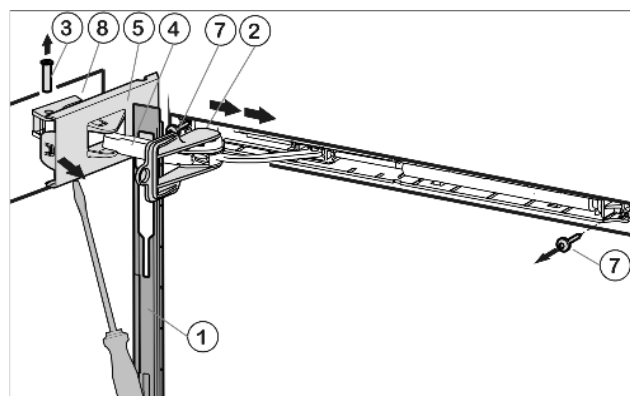

Fig. 5

- ▶ Slide the faceplate forwards over the soft stop bracket Fig. 5 (4) in the direction of the appliance.
- ▶ Snap the accompanying safety lock Fig. 5 (2) into the oblong hole.
- ▶ The safety lock prevents the hinge from snap-closing.
- ▶ Using a screwdriver, detach the cover Fig. 5 (5) on the hinge side as far as the first detent.
- ▶ The pin becomes visible.
- ▶ Press the pin Fig. 5 (3) out from underneath.
- ▶ Press the soft stop bracket Fig. 5 (4) towards the door.
- ▶ Fully detach the cover Fig. 5 (5) on the hinge side and remove it.
- ▶ Remove the faceplate Fig. 5 (1).

- ▶ Using a screwdriver, detach the cover on the handle side *Fig. 6 (6)* and remove it outwards.

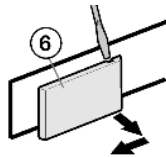

Fig. 6

- ▶ Unscrew the soft stop unit (2x Torx 15) *Fig. 5 (7)*.
- ▶ Pull the soft stop unit out a little, push it in the direction of the handle side and swing it out.
- ▶ Set the soft stop unit aside.
- ▶ Unscrew the bearing element *Fig. 5 (8)*, turn it 180° and transfer it to the opposite side. Possibly make preliminary holes with a bradawl or use a cordless screwdriver.

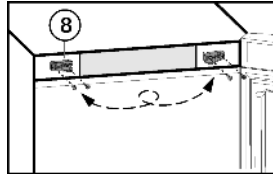

Fig. 7

4.1.2 Detaching the lower soft stop mechanism

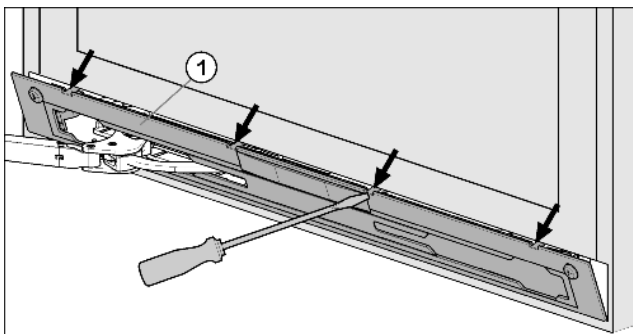

Fig. 8

- ▶ Open the door.

NOTICE

Risk of damage!

If the door seal is damaged, the door may fail to close properly and the cooling will be inadequate.

- ▶ Do not damage the door seal with the screwdriver!

- ▶ Disengage and remove the faceplate *Fig. 8 (1)* using a flat-blade screwdriver.
- ▶ The faceplate is attached over the soft stop bracket.

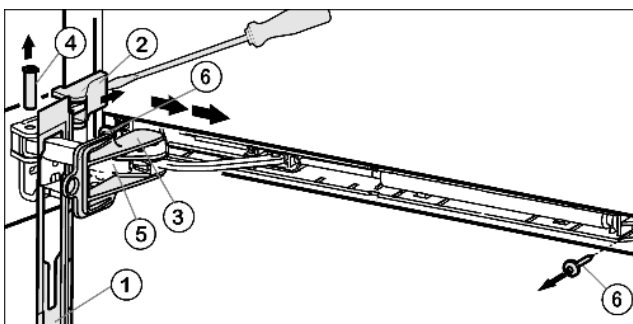

Fig. 9

- ▶ Slide the faceplate forwards over the soft stop bracket *Fig. 9 (5)* in the direction of the appliance.
- ▶ Snap the safety lock *Fig. 9 (3)* into the oblong hole.
- ▶ The safety lock prevents the hinge from snap-closing.
- ▶ Using a screwdriver, lift off the cover *Fig. 9 (2)* from the outside and remove it in an outward direction.
- ▶ If necessary, tip the appliance backwards with the assistance of a second person.
- ▶ Press the pin *Fig. 9 (4)* out from underneath.
- ▶ Press the soft stop bracket *Fig. 9 (5)* towards the door.
- ▶ Remove the faceplate *Fig. 9 (1)*.
- ▶ Unscrew the entire soft stop unit (2x Torx 15) *Fig. 9 (6)*.
- ▶ Pull the soft stop unit out a little, push it in the direction of the handle side and swing it out.

- ▶ Set the soft stop unit aside.

4.1.3 Detaching the door

Note

- ▶ Remove any food from the door racks before removing the door, so that no food falls out.

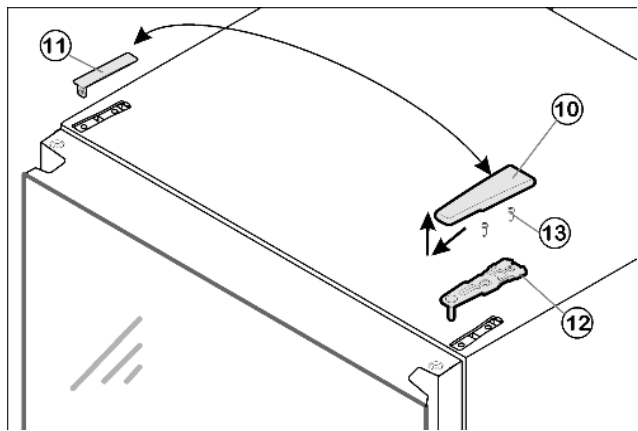

Fig. 10

- ▶ Close the door.
- ▶ Pull off the cover *Fig. 10 (10)* forwards and upwards.
- ▶ Lift off the cover *Fig. 10 (11)*.



CAUTION

Risk of injury if the door tips!

- ▶ Take good hold of the door.
- ▶ Set down the door carefully.

- ▶ Unscrew the upper turn hinge *Fig. 10 (12)* (2x Torx 25) *Fig. 10 (13)* and raise it for removal.

4.1.4 Changing the freezer compartment door

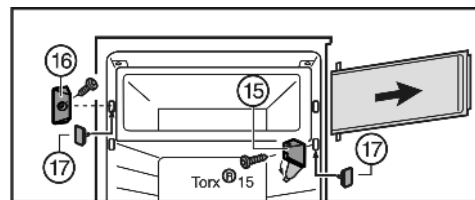

Fig. 11

- ▶ Fold away the cover of the turn hinge *Fig. 11 (15)*.
- ▶ Unscrew turn hinge *Fig. 11 (15)* together with compartment door.
- ▶ Unscrew closing element *Fig. 11 (16)*.
- ▶ Close the vacated holes with the accompanying stoppers *Fig. 11 (17)*.

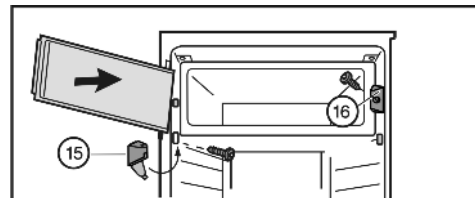

Fig. 12

- ▶ Fit the closing element *Fig. 12 (16)*.
- ▶ Fit the compartment door at the top.
- ▶ Fit the turn hinge *Fig. 12 (15)* and fold the cover.

Putting into operation

4.1.5 Transferring bearing parts

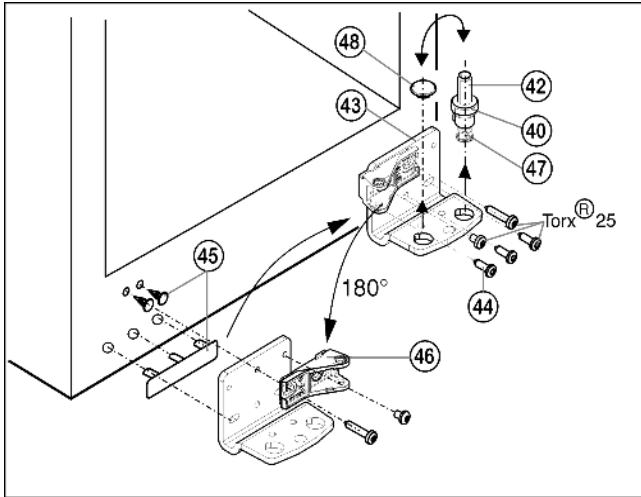

Fig. 13

- ▶ Lift out the bearing pin Fig. 13 (42) together with washer Fig. 13 (40) and adjustable-height foot Fig. 13 (47).
- ▶ Lift off the stopper Fig. 13 (48).
- ▶ Unscrew the turn hinge Fig. 13 (43).
- ▶ Carefully lift off the cover on the handle side Fig. 13 (45) and transfer it to the opposite side.
- ▶ Screw the bottom turn hinge Fig. 13 (43) firmly into place (with 4 Nm) on the new hinge side, possibly using a cordless screwdriver.
- ▶ Unscrew the bearing element Fig. 13 (46), turn it through 180° and screw it back firmly into place, always screw the long screw into the oblong hole.
- ▶ Re-insert the stopper Fig. 13 (48) into the other hole.
- ▶ Re-insert the bearing pin Fig. 13 (42) together with the washer and adjustable-height foot. In so doing, pay attention that the locating lug points backwards

4.1.6 Fitting the door

- ▶ Place the door from above onto the lower bearing pin Fig. 13 (42).
- ▶ Close the door.
- ▶ Insert the upper turn hinge Fig. 10 (12) in the door on the new hinge side.
- ▶ Screw the upper turn hinge Fig. 10 (12) firmly into place (with 4 Nm)(2x Torx 25) Fig. 10 (13). Possibly make preliminary holes with a bradawl or use a cordless screwdriver.
- ▶ Snap the cover Fig. 10 (10) and cover Fig. 10 (11) into place at the opposite side.

4.1.7 Fitting the lower soft stop mechanism

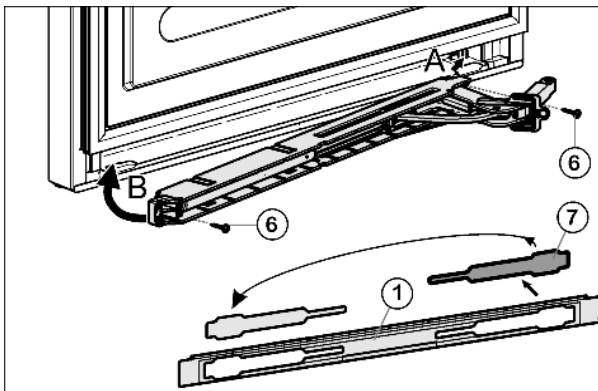

Fig. 14

- ▶ Remove the cover Fig. 14 (7) from the faceplate Fig. 14 (1) and re-insert it at the other side.
- ▶ Engage the soft stop unit with the joint pointing to the hinge side (A) and swivel into place (B).

- ▷ The screw holes at the left and right have to register.
- ▶ Screw down the soft stop unit (2x Torx 15) Fig. 14 (6).

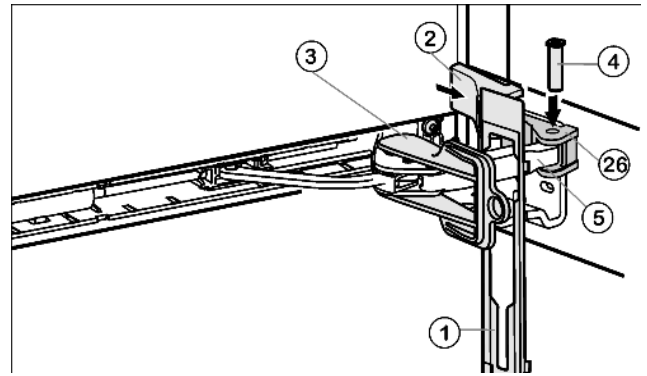

Fig. 15

- ▶ Attach the faceplate Fig. 15 (1) to the soft stop bracket so that the catches face forwards and the front faces the appliance.
- ▶ Draw the soft stop bracket Fig. 15 (5) towards the bearing part Fig. 15 (26) and re-insert the pin Fig. 15 (4) from above so that the square sits in the recess.
- ▶ Attach and engage the cover Fig. 15 (2).
- ▷ Pay attention that the cover fits properly so that the door closes properly and the pin is secured.
- ▶ Twist the safety lock Fig. 15 (3) for removal.
- ▶ Slide the faceplate Fig. 15 (1) onto the door and snap it into place.
- ▶ Close the door.

4.1.8 Fitting the upper soft stop mechanism

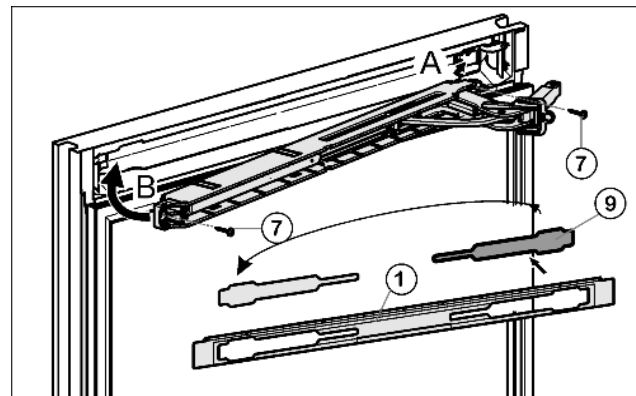

Fig. 16

- ▶ Remove the cover Fig. 16 (9) from the faceplate Fig. 16 (1) and re-insert it at the other side.
- ▶ Engage the upper soft stop unit with the joint on the hinge side (A) and swivel into place (B).
- ▷ The screw holes at the left and right have to register.
- ▶ Screw down the soft stop unit (2x Torx 15 Fig. 16 (7)).

Note

- ▶ Keep to the correct order. First attach the panel over the soft stop bracket, then the cover.

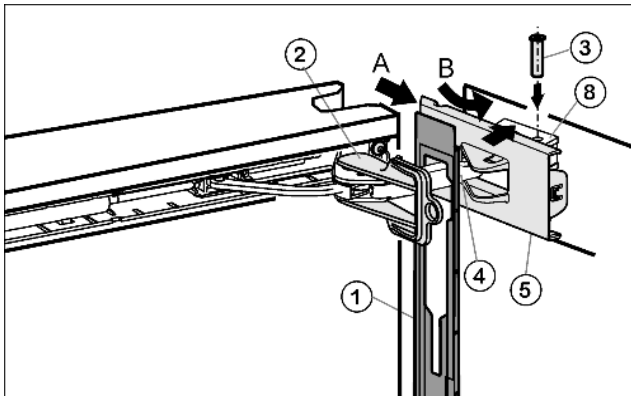

Fig. 17

- ▶ Attach the faceplate Fig. 17 (1) to the soft stop bracket Fig. 17 (4) so that the catches face inwards and the front faces the appliance.
- ▶ Slide on the cover Fig. 17 (5) from the outside (A) and swivel it over the bearing part Fig. 17 (8) (B).
- ▶ Attach the cover Fig. 17 (5) and engage it as far as the first detent.
- ▷ The openings for the pin are on top of one another after the soft stop bracket has been positioned.
- ▶ Draw the soft stop bracket Fig. 17 (4) towards the bearing part and insert the pin Fig. 17 (3) from above so that the square sits in the recess.
- ▶ Now completely snap the cover Fig. 17 (5) onto the bearing part Fig. 17 (8).
- ▷ Pay attention that the cover fits properly so that the door closes properly and the pin is secured.
- ▶ Twist the safety lock Fig. 17 (2) for removal.
- ▶ Slide the faceplate Fig. 17 (1) onto the door and snap it into place.
- ▶ Turn the cover Fig. 6 (6) through 180°, attach and engage it on the handle side.

4.1.9 Aligning the door

- ▶ If necessary, align the door to the appliance housing by way of the oblong holes in the bottom turn hinge Fig. 13 (43). To do so, unscrew the middle screw.



WARNING

Risk of injury due to the door dropping out!
If the bearing parts are not screwed into place firmly enough, the door may drop out. This may lead to severe injuries. What is more, the door may not close and therefore the appliance may fail to cool properly.

- ▶ Screw the turn hinges firmly into place with 4 Nm.
- ▶ Check all of the screws and retighten if necessary.

4.2 Insertion into a row of kitchen units

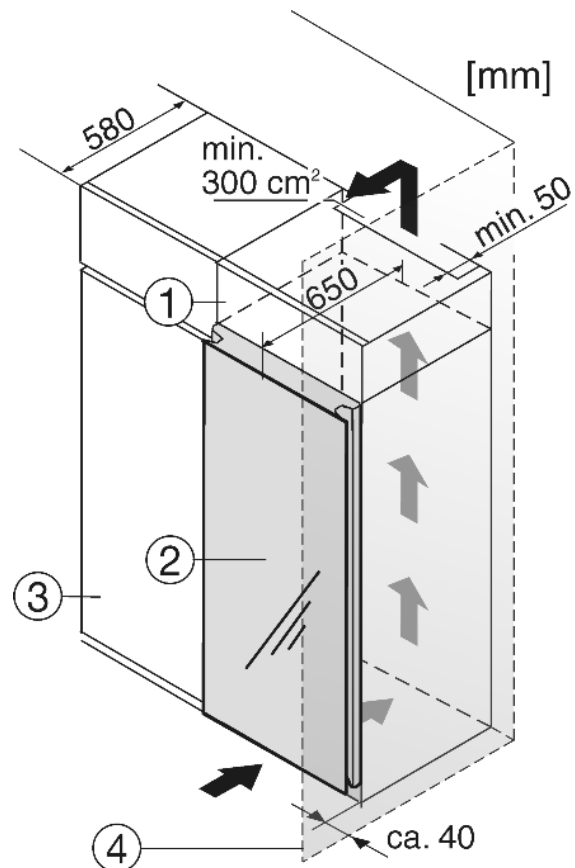

Fig. 18

- (1) Stack cabinet
- (2) Appliance
- (3) Kitchen cabinet
- (4) Wall

When inserting the appliance into a row of standard kitchen units (max. depth 580 mm), the appliance can be installed directly next to the kitchen unit Fig. 18 (3). The appliance door projects 70 mm relative to the front of the kitchen units. It can be opened and closed perfectly as a result.

Important for the ventilation:

- At the back of the stack cabinet there has to be a ventilation duct of at least 50 mm depth throughout the width of the stack cabinet.
- The ventilation space under the ceiling has to be at least 300 cm².
- The larger the ventilation space, the more energy-saving the appliance is in operation.

If the appliance is installed with the hinges next to a wall Fig. 18 (4), the distance between appliance and wall has to be at least 40 mm.

4.3 Transporting the appliance



CAUTION

Risk of injury and danger of damage as a result of incorrect transport!

- ▶ Transport the appliance in a packed condition.
- ▶ Transport the appliance upright.
- ▶ Do not transport the appliance without assistance.

4.4 Installing the appliance

In the event that the appliance is damaged, contact the supplier immediately before connecting to the mains.

The floor at the site must be flat and level.

Putting into operation

Do not install the appliance in a location where it is exposed to direct radiation of the sun, next to a cooker, heater and similar.

Always install the appliance with the back directly against the wall.

Do not install the appliance without assistance.

Standard EN 378 specifies that the room in which you install your appliance must have a volume of 1 m² per 8 g of R 600a refrigerant used in the appliance. If the room in which the appliance is installed is too small, a flammable gas-air mixture may form in the event of a leakage in the refrigeration circuit. The quantity of refrigerant used in your appliance is indicated on the type plate on the inside of the appliance.



CAUTION

Risk of injury and damage!

The glass door may strike against the wall and be damaged as a result. The fractured glass may lead to injury!

- ▶ Protect the glass door from striking against the wall. Fit a door stop, e.g. one made of felt, to the wall.
- ▶ A limiter restricting door opening to 90° can be ordered from the aftersales service.



WARNING

Fire hazard due to dampness!

If live parts or the mains lead become damp this may cause short circuits.

- ▶ The appliance is designed for use in enclosed areas. Do not operate the appliance outdoors or in areas where it is exposed to splash water or damp conditions.



WARNING

Fire hazard due to refrigerant!

The refrigerant R 600a is environmentally friendly but flammable. Escaping refrigerant may ignite.

- ▶ Do not damage the piping of the refrigeration circuit.



WARNING

Fire hazard and danger of damage!

- ▶ Do not place appliances emitting heat e.g. microwaves, toasters etc. on the appliance!



WARNING

Blocked ventilation openings pose a risk of fire and damage!

- ▶ Always keep the ventilation openings clear. Always ensure that the appliance is properly ventilated!

- ▶ Detach the connecting cable from the rear of the appliance, removing the cable holder at the same time because otherwise there will be vibratory noise!
- ▶ Remove the protective film from the outside of the appliance.*
- ▶ Evenly apply an agent for care of stainless steel, wiping in the direction of the grain.*
- ▷ Subsequent cleaning becomes easier as a result.*
- ▶ Remove the protective film from the decorative trims.
- ▶ Remove all transit supports.
- ▶ Dispose of packaging material (see 4.5) .

NOTICE

Risk of damage due to condensate!

- ▶ Do not install the appliance directly alongside a further refrigerator/freezer.

- ▶ Align the appliance so that it stands firmly and on a level by applying the accompanying spanner to the adjustable-height feet (A) and using a spirit level.

- ▶ Then support the door: Extend the adjustable foot at the turn hinge (B) until it rests on the floor and then make a further 90° turn.

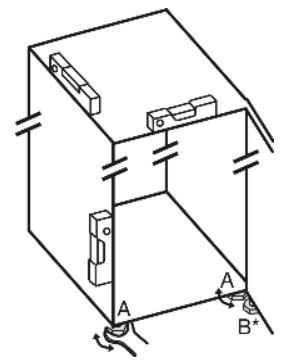

If the appliance is installed in a very damp environment, condensate may form on the outside of the appliance.

- ▶ Always see to good ventilation at the installation site.

4.5 Disposing of packaging



WARNING

Danger of suffocation due to packing material and plastic film!

- ▶ Do not allow children to play with packing material.

The packaging is made of recyclable materials:

- corrugated board/cardboard
- expanded polystyrene parts
- polythene bags and sheets
- polypropylene straps

- ▶ Take the packaging material to an official collecting point.



4.6 Connecting the appliance

NOTICE

Risk of damage to the electronic control system!

- ▶ Do not use stand-alone inverters (conversion of d.c. to a.c./ three-phase) or energy saving plugs.



WARNING

Fire and overheating hazard!

- ▶ Do not use extension cables or multiple socket outlets.

The type of current (alternating current) and voltage at the installation site have to conform with the data on the type plate (see Appliance at a glance).

Connect the appliance only with a properly installed socket outlet with earthing contact. The socket outlet must be fused with 10 A or higher.

It must be easily accessible so that the appliance can be quickly disconnected from the supply in an emergency.

- ▶ Check the electrical connection.
- ▶ Clean the appliance (see 6.2) .
- ▶ Plug in the power plug.



4.7 Switching on the appliance

Put the appliance into operation about 2 hours before first loading food to be frozen.

- ▶ Press On/Off button *Fig. 3 (3)*.
- ▷ The temperature display indicates the current temperature.
- ▷ The interior light is on when the door is open.

5 Control

5.1 Brightness of the temperature display

You can adjust the brightness of the temperature display to the light conditions of the room in which the appliance is installed.

5.1.1 Adjusting the brightness

The brightness is adjustable between h0 (no illumination) and h5 (maximum luminosity).

- ▶ To activate the setting mode: press SuperCool button *Fig. 3 (2)* for about 5s.
- ▷ The display indicates c.
- ▷ The menu symbol *Fig. 3 (5)* shines.
- ▶ Using the Up setting button *Fig. 3 (7)* and Down setting button *Fig. 3 (6)*, select h.
- ▶ To confirm: briefly press the SuperCool button *Fig. 3 (2)*.
- ▶ To set the display brighter: press the Up setting button *Fig. 3 (7)*.
- ▶ To set the display darker: press the Down setting button *Fig. 3 (6)*.
- ▶ To confirm: briefly press the SuperCool button *Fig. 3 (2)*.
- ▷ The brightness is adjusted to the new value.
- ▶ To deactivate the setting mode: press the On/Off button *Fig. 3 (3)*.

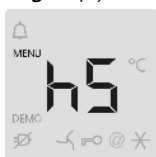

-or-

- ▶ Wait for 5 minutes.
- ▷ The temperature is indicated again in the temperature display.

5.2 Child proofing

The child-proofing function enables you to make sure that the appliance is not inadvertently switched off by playing children.

5.2.1 Setting the child lock function

- ▶ To activate the setting mode: press SuperCool button *Fig. 3 (2)* for about 5 s.
- ▷ The display indicates c.
- ▷ The menu symbol *Fig. 3 (5)* shines.
- ▶ Briefly press the SuperCool button *Fig. 3 (2)* to confirm. When c1 is indicated in the display:
- ▶ to activate the child lock, briefly press the SuperCool button *Fig. 3 (2)*.

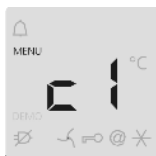

- ▷ The child lock symbol *Fig. 3 (12)* shines. c flashes in the display.
- When c0 is indicated in the display:
- ▶ to deactivate the child lock, briefly press the SuperCool button *Fig. 3 (2)*.
- ▷ The child lock symbol *Fig. 3 (12)* goes out. c flashes in the display.
- ▶ To deactivate the set-up mode: press On/Off button *Fig. 3 (3)*.

-or-

- ▶ Wait for 5 minutes.
- ▷ The temperature is indicated again in the temperature display.

5.3 Door alarm

If the door is open longer than 60 s, the audible alarm sounds.

The audible alarm is automatically silenced when the door is closed.

5.3.1 Muting the door alarm

The audible alarm can be muted when the door is open. The sound switch-off function is active as long as the door is left open.

- ▶ Press alarm button *Fig. 3 (1)*.
- ▷ The door alarm is silenced.

5.4 Refrigerator compartment

The natural circulation of air in the refrigerator compartment results in zones differing in temperature. It is coldest directly above the plate separating off the BioFresh zone and at the rear wall. It is warmest at the top front of the compartment and in the door.

5.4.1 Food refrigeration

Note

The energy consumption increases and the cooling performance decreases if the ventilation is inadequate.

- ▶ Always keep the air slits of the fan free.

- ▶ Place butter and preserves in the upper area and in the door (see Appliance at a glance).
- ▶ Use recyclable plastic, metal, aluminium and glass containers and cling film for wrapping.

For appliances from 1216 mm high:

- ▶ Use the front area of the refrigerator compartment floor only for briefly putting down cooled products, e.g. when rearranging and sorting. However do not leave cooled products there otherwise they may be pushed back or tipped over when the door is closed.
- ▶ Do not store food too close together to enable good air circulation.
- ▶ To safeguard bottles from tipping over: move the bottle holder.

At the base of the refrigerator compartment, the integrated bottle shelf or alternatively the glass shelf can be used:

- ▶ To use the bottle shelf: store the glass shelf compactly under the bottle shelf.
- ▶ Place the bottles with the base pointing backwards facing the rear wall. If the bottles project beyond the bottle shelf:
- ▶ set the lower door rack one position higher.

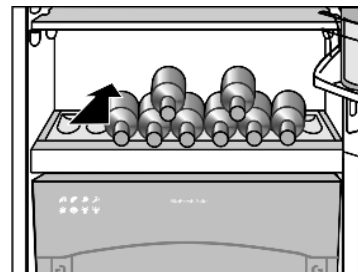

5.4.2 Setting the temperature

The temperature can be set from 9 °C to 3 °C, the recommended temperature is 5 °C.

An average temperature of about -18 °C is reached in the freezer compartment.

- ▶ For a higher temperature setting: press Up button *Fig. 3 (7)*.
- ▶ For a lower temperature setting: press Down button *Fig. 3 (6)*.
- ▷ The first time the button is pressed, the value set so far is indicated in the temperature display.
- ▶ To change the temperature in 1 °C steps: briefly press the button.
- ▶ To change the temperature continuously: hold down the button.
- ▷ The value is displayed flashing during the setting operation.
- ▷ The actual temperature is displayed about 5 s after the last press of a button. The temperature slowly adjusts to the new value.

Control

5.4.3 SuperCool

With SuperCool you switch to the highest cooling performance to reach lower cooling temperatures. Use SuperCool, to rapidly cool large amounts of food.

The SuperCool function uses slightly more energy.

Cooling with SuperCool

- ▶ Briefly press SuperCool button *Fig. 3 (2)*.
- ▷ The SuperCool symbol *Fig. 3 (11)* lights up in the display.
- ▷ The cooling temperature drops to the coldest value. SuperCool is activated.
- ▷ SuperCool is automatically deactivated after 6 to 12 hours. The appliance continues to operate in the energy-saving, normal mode.

To prematurely deactivate SuperCool

- ▶ Briefly press SuperCool button *Fig. 3 (2)*.
- ▷ The SuperCool symbol *Fig. 3 (11)* goes out in the display.
- ▷ SuperCool is deactivated.

5.4.4 Relocating the shelves

The shelves have stops preventing them from being unintentionally pulled out.

- ▶ Lift the shelf and draw it out forwards.

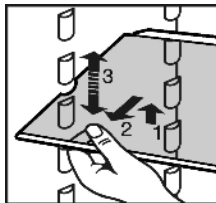

- ▶ Insert shelf with the raised edge pointing upwards at the back.
- ▷ The food does not freeze onto the rear wall.

5.4.5 Using the sectioned shelf

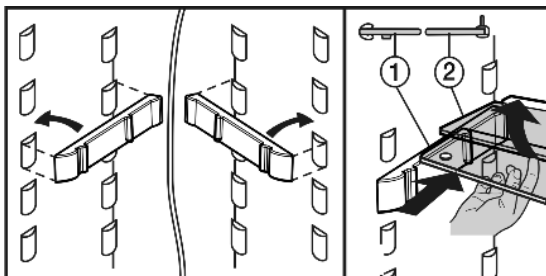

- ▶ The glass shelf with stop face (2) has to be at the back.

5.4.6 Moving the storage rack

- ▶ Remove storage rack according to illustration.

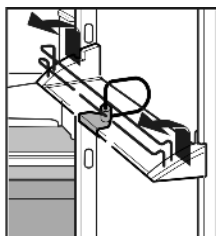

The boxes can be removed and placed on the table as a single unit.

Only one box or both boxes can be used. If particularly tall bottles are to be stored, attach only the wide box above the bottle rack.

Three small boxes are available through the customer service as optional equipment instead of one wide and one small box.

- ▶ Re-positioning the boxes: Lift them for removal and re-position them as required.

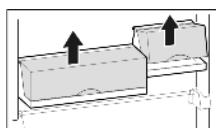

- ▶ To detach lid: Open 90° and raise to disengage.

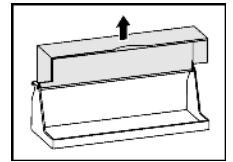

5.4.7 Removing the bottle holder

- ▶ Always take hold of the bottle holder on the plastic part.

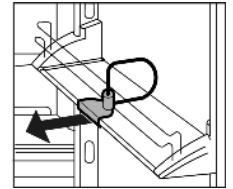

5.5 BioFresh compartment

The BioFresh compartment allows some types of fresh food to be stored up to three times longer than in conventional refrigerators, without compromising quality.

For food with an indicated best before date, the date specified on the packaging always applies.

5.5.1 HydroSafe

The HydroSafe at the moist setting is suited for storing unwrapped salad, vegetables and fruit with high inherent moisture. When the drawer is well filled, a dewy climate with up to 90% humidity is established. The humidity in the compartment depends on the moisture content of the food stored and on the opening frequency. You can set the humidity yourself.

5.5.2 DrySafe

The DrySafe is suitable for storing dry or wrapped food (e.g. dairy products, meat, fish, sausages). A relatively dry storage climate is established here.

5.5.3 Storing food

Note

- ▶ Vegetables sensitive to cold, such as cucumbers, aubergines, semi-ripe tomatoes, zucchinis and all tropical fruits sensitive to cold, do not belong in the BioFresh compartment.

- ▶ To prevent food spoilage due to transfer of germs: Store unwrapped animal and vegetable products separate from one another in the drawers. This also applies to different sorts of meat.

- If food has to be stored together due to lack of space:
 - ▶ wrap the food.

5.5.4 Storage times

Standard values for storage time at low humidity			
Butter	up to	90	days
Hard cheese	up to	110	days
Milk	up to	12	days
Sausage, cold meat	up to	9	days
Poultry	up to	6	days
Pork	up to	7	days
Beef	up to	7	days
Game	up to	7	days

Note

- Please note that protein-rich food deteriorates faster, i.e. shellfish and crustaceans deteriorate faster than fish, fish faster than meat.

Standard values for storage time at high humidity			
Vegetables, salad			
Artichokes	up to	14	days
Celery	up to	28	days
Cauliflower	up to	21	days
Broccoli	up to	13	days
Chicory	up to	27	days
Lamb's lettuce	up to	19	days
Peas	up to	14	days
Kale	up to	14	days
Carrots	up to	80	days
Garlic	up to	160	days
Kohlrabi	up to	55	days
Lettuce	up to	13	days
Herbs	up to	13	days
Leek	up to	29	days
Mushrooms	up to	7	days
Radishes	up to	10	days
Brussels sprouts	up to	20	days
Asparagus	up to	18	days
Spinach	up to	13	days
Savoy cabbage	up to	20	days
Fruit			
Apricots	up to	13	days
Apples	up to	80	days
Pears	up to	55	days
Blackberries	up to	3	days
Dates	up to	180	days
Strawberries	up to	7	days
Figs	up to	7	days
Blueberries	up to	9	days
Raspberries	up to	3	days
Currants	up to	7	days
Sweet cherries	up to	14	days
Kiwis	up to	80	days
Peaches	up to	13	days
Plums	up to	20	days
Cranberries	up to	60	days
Rhubarb	up to	13	days
Gooseberries	up to	13	days
Grapes	up to	29	days

5.5.5 Adjusting the temperature in the BioFresh compartment

The temperature is automatically regulated to between 0 °C and 3 °C, the recommended temperature is 1 °C.

You can adjust the temperature slightly colder or warmer. The temperature can be adjusted from ❶ (coldest temperature) to ❸ (warmest temperature). The presetting is ❷. At the ❶ to ❸ settings the temperature may drop below 0 °C and therefore the food may freeze slightly.

Note

for testing institutes: If temperatures below 3 °C are to be reached in the refrigerator compartment:

- set the temperature in the BioFresh compartment to b1-b4.
- To activate the setting mode: press the SuperCool button *Fig. 3 (2)* for about 5 s.
- ▷ The menu symbol *Fig. 3 (5)* shines. The temperature display indicates c .
- Using the Up setting button *Fig. 3 (7)* or Down setting button, *Fig. 3 (6)* select ❷.
- To confirm: briefly press the SuperCool button *Fig. 3 (2)*.
- For a warmer temperature adjustment: press Up setting button *Fig. 3 (7)*.
- For a colder temperature adjustment: press Down setting button *Fig. 3 (6)*.
- To confirm: press SuperCool button *Fig. 3 (2)*.
- ▷ The temperature slowly adjusts to the new value.

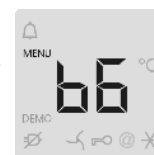



- To deactivate the setting mode: press the On/Off button *Fig. 3 (3)*.

-or-

- Wait for 5 minutes.
- ▷ The temperature is indicated again in the temperature display.

5.5.6 Setting the humidity in the HydroSafe

-  Low humidity: move the regulator to the left.
-  High humidity: move the regulator to the right.



5.5.7 Drawers

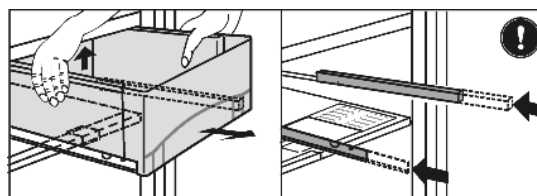

Fig. 20

- Pull out the drawer, lift it at the back and draw it forwards for removal.
- Push the rails in again!

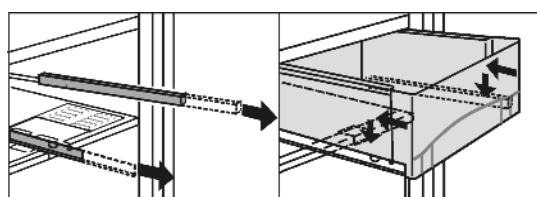

Fig. 21

- Pull out the rails.
- Attach the drawer to the rails and push it in until it engages audibly at the back.

Maintenance

5.5.8 Humidity control plate

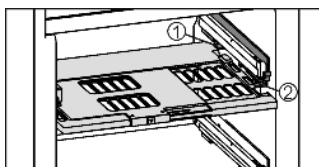

Fig. 22

- ▶ To remove the humidity control plate: Having removed the drawers, carefully draw the plate forwards and lower it for removal.
- ▶ To insert the humidity control plate: Insert the cover mouldings of the plate into the rear holder *Fig. 22 (1)* from underneath and engage them in the holder *Fig. 22 (2)* at the front.

5.6 Freezer compartment

You can store frozen food for several months, make ice cubes and freeze fresh food in the freezer compartment at a temperature of $-18\text{ }^{\circ}\text{C}$ and lower.

The air temperature in the compartment, measured by thermometer or other instruments, may fluctuate.

5.6.1 Freezing food



CAUTION

Risk of injury due to broken glass!
Bottles and cans containing drinks may burst when being frozen. This applies particularly to sparkling drinks.

- ▶ Do not freeze bottles and cans containing drinks!

In order that the food is rapidly frozen through to the core, do not exceed the following quantities per pack:

- Fruit, vegetables up to 1 kg
- Meat up to 2.5 kg
- ▶ Pack the food in portions in freezer bags, reusable plastic, metal or aluminium containers.
- ▶ Spread the food over the shelf. Do not allow it to contact and thaw items that are already frozen.

5.6.2 Storage times

Guide times for storing various types of food in the freezer compartment:	
Ice cream	2 to 6 months
Sausage, ham	2 to 6 months
Bread, bakery products	2 to 6 months
Game, pork	6 to 10 months
Fish, fatty	2 to 6 months
Fish, lean	6 to 12 months
Cheese	2 to 6 months
Poultry, beef	6 to 12 months
Vegetables, fruit	6 to 12 months

Storage times given are guide times.

5.6.3 Thawing food

- in the refrigerator compartment
- at room temperature
- in a microwave oven
- in a conventional or fan oven
- ▶ Food once thawed should be re-frozen only in exceptional cases.

5.6.4 SuperFrost

With this function you can freeze fresh food quickly through to the core. The appliance operates with maximum refrigeration. The noise of the refrigeration unit may be temporarily louder as a result.

In addition, frozen food already in storage is given a "cold reserve". The food stays frozen longer as a result when you defrost the appliance.

The maximum amount of fresh food which can be frozen in 24 h is indicated on the type plate under "freezing capacity ... kg/24h". This amount varies according to the model and climate rating.

Freezing with SuperFrost

SuperFrost in the following cases:

- when placing frozen food in the freezer
- when freezing up to about 2 kg fresh food a day
- ▶ Briefly press the SuperFrost button *Fig. 3 (8)* once.
- ▷ The SuperFrost symbol *Fig. 3 (13)* shines.
- ▷ The freezer temperature drops, the appliance operates with maximum refrigerating performance.
 - For a small amount of food:
 - ▶ wait about 6 h.
 - For the maximum amount of food:
 - ▶ wait about 24 h.
- ▶ Spread the food over the shelf. Do not allow it to contact and thaw items that are already frozen.
- ▷ SuperFrost is automatically deactivated. Depending on the quantity placed inside, after 30 h at the earliest, 65 h at the latest.
- ▷ The SuperFrost symbol *Fig. 3 (13)* goes out.
- ▷ The appliance continues to operate in the energy-saving, normal mode.

6 Maintenance

6.1 Defrosting

6.1.1 Defrosting refrigerator compartment

The refrigerator compartment is defrosted automatically. The water evaporates. Drops of water on the rear wall are functionally conditioned and perfectly normal.

- ▶ Clean the drain hole at regular intervals to allow the defrost water to drain (see 6.2).

6.1.2 Defrosting freezer compartment

A layer of frost and ice forms in the freezer compartment after the appliance has been in use for a lengthy period of time. This is quite normal. The layer of frost and ice forms more quickly if the door is opened frequently or if the food is warm when placed inside. However, a thick layer of ice will increase the appliance's energy consumption. You should therefore defrost the appliance regularly.



CAUTION

Risk of injury and damage as a result of hot steam!

- ▶ Do not use electric heaters or steam cleaners, naked flames or defrosting sprays for defrosting.
- ▶ Do not remove ice using sharp instruments.
- ▶ Switch on SuperFrost one day before defrosting.
- ▶ Switch off the appliance.
- ▷ The temperature display goes out.
- ▷ If the temperature display does not go out, the child-proofing function (see 5.2) is active.
- ▶ Pull out the plug.

- ▶ Wrap the frozen food in newspaper or blankets and store in a cool place.
- ▶ Place a pan with hot, not boiling water on the floor of the compartment.
- ▷ Defrosting is speeded up.
- ▶ Leave the compartment and appliance door open during defrosting.
- ▶ Remove detached pieces of ice.
- ▶ If necessary, pick up defrost water several times, using a sponge or cloth.
- ▶ Clean the compartment (see 6.2).

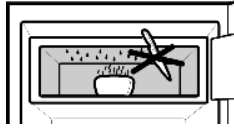

- ▶ To dismantle the shelves: remove the trims and side parts.
- ▶ To dismantle the storage rack: remove the protective film from the decorative trims.
- ▶ Lift out the boxes and lift the covers for removal.

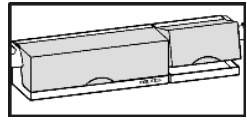
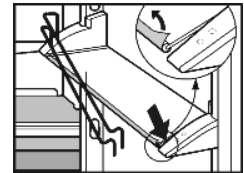

6.2 Cleaning the appliance

Before cleaning:



CAUTION

Risk of injury and damage as a result of hot steam! Hot steam may damage the surfaces and cause burns.

- ▶ Do not use any steam cleaners!

NOTICE

Incorrect cleaning damages the appliance!

- ▶ Do not use cleaning agents in concentrated form.
- ▶ Do not use any scouring or abrasive sponges or steel wool.
- ▶ Do not use any cleaning agents containing sand, chloride, chemicals or acid.
- ▶ Do not use chemical solvents.
- ▶ Do not damage or remove the type plate on the inside of the appliance. It is important for the customer service.
- ▶ Do not pull off, bend or damage cables or other components.
- ▶ Do not allow any cleaning water to enter the drain channel, ventilation grille or electrical parts.

- ▶ Empty the appliance.
- ▶ Pull out the plug.

- Use soft cleaning cloths and a multi-purpose cleaning agent with neutral pH value.
- Only use food compatible cleaning and care agents on the inside of the appliance.

- ▶ Regularly clean ventilation grilles.
- ▷ Dust deposits increase energy consumption.



Outside surfaces and interior:

Do not clean the glass door with abrasive cleaning agents or rough cloths. Otherwise the surface and the frame may become dull or be scratched.

- ▶ Clean the glass door with a standard glass cleaning agent and a soft cloth.
- ▶ Clean the plastic surfaces, outside and inside, by hand using lukewarm water and a little washing-up liquid.
- ▶ If outer stainless steel surfaces are dirty, clean them using a commercially available stainless steel cleaner. Then evenly apply the accompanying stainless steel care product, making strokes in the direction of the grain.

Do not apply stainless steel cleaning agent to glass or plastic surfaces to prevent them from being scratched. Darker areas at the beginning and quite an intensive colour of the stainless steel surface are normal.

- ▶ To clean the drain opening: remove any deposits with a fine instrument, e.g. a cotton bud.

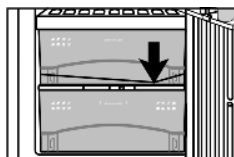

Items of equipment:

- ▶ Clean items of equipment by hand with lukewarm water and a little washing-up liquid.
- ▶ For cleaning, remove the support rails for the half-sized glass shelves.

After cleaning:

- ▶ Wipe dry the appliance and items of equipment.
- ▶ Connect the appliance and switch it on again.
- ▶ Switch on SuperFrost (see 5.6.4).
- ▶ Put the food back inside.

6.3 Customer service

First check whether you can correct the fault yourself by reference to the list (see Malfunction). If this is not the case, please contact the customer service whose address is given in the enclosed customer service list.



WARNING

Risk of injury if repair work is not carried out professionally!

- ▶ Have any repairs to and intervention in the appliance and mains power cable, which are not expressly mentioned in the (see Maintenance) carried out by the customer service only.

- ▶ Read the appliance designation *Fig. 23 (1)*, service No. *Fig. 23 (2)* and serial No. *Fig. 23 (3)* off the type plate located inside the appliance on the left-hand side.

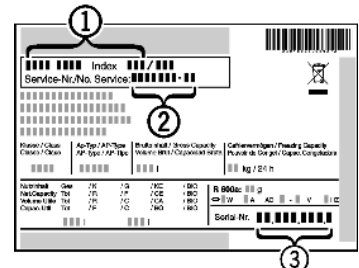

Fig. 23

- ▶ Notify the customer service, specifying the fault, appliance designation *Fig. 23 (1)*, service No. *Fig. 23 (2)* and serial No. *Fig. 23 (3)*.
- ▷ This will help us to provide you with a faster and more accurate service.
- ▶ Keep the appliance closed until the customer service arrives.
- ▷ The food will stay cool longer.
- ▶ Pull out the mains plug (not by pulling the connecting cable) or switch off the fuse.

7 Malfunction

Your appliance is designed and manufactured for a long life span and reliable operation. If a malfunction nonetheless occurs during operation, check whether it is due to a handling error. In this case you will have to be charged for the costs incurred, even during the warranty period. You may be able to rectify the following faults yourself:

Appliance does not work.

- The appliance is not switched on.
- ▶ Switch on the appliance.
- The power plug is not properly inserted in the wall socket.
- ▶ Check power plug.
- The fuse of the wall socket is not in order.
- ▶ Check fuse.

Decommissioning

The compressor runs for a long time.

- The compressor switches to a low speed when little cold is needed. Although the running time is increased as a result, energy is saved.
- ▶ This is normal in energy-saving models.
- SuperFrost is activated.
- ▶ The compressor runs for longer in order to rapidly cool the food. This is normal.
- SuperCool is activated.
- ▶ The compressor runs for longer in order to rapidly cool the food. This is normal.

Excessive noise.

- Speed-controlled* compressors may produce varying running noise due to different speed steps.
- ▶ The sound is normal.

A bubbling and gurgling noise.

- This noise comes from the refrigerant flowing in the refrigeration circuit.
- ▶ The sound is normal.

A quiet clicking noise.

- The noise is produced whenever the refrigeration unit (motor) automatically switches on or off.
- ▶ The sound is normal.

A hum. It is briefly a little louder when the refrigeration unit (the motor) switches on.

- The refrigeration increases automatically when the SuperFrost, function is activated, fresh food has just been placed in the appliance or the door has been left open for a while.
- ▶ The sound is normal.
- The refrigeration increases automatically when the SuperCool function is activated, fresh food has just been placed in the appliance or the door has been left open for a while.
- ▶ The sound is normal.
- The ambient temperature is too high.
- ▶ Solution: (see 1.2)

A low hum.

- The sound is produced by air flow noise of the fan.
- ▶ The sound is normal.

Vibratory noise.

- The appliance is not standing firmly on the floor. As a result, adjoining units or objects are set into vibration by the running refrigeration unit.
- ▶ Move the appliance away a little and align it using the adjustable feet.
- ▶ Move bottles and containers apart.

The temperature display indicates: F0 to F9

- There is a fault.
- ▶ Contact the customer service. (see Maintenance).

DEMO shines in the temperature display.

- The demo mode is activated.
- ▶ Contact the customer service. (see Maintenance).

The temperature is not cold enough.

- The door of the appliance is not properly closed.
- ▶ Close the door of the appliance.
- Insufficient ventilation.
- ▶ Clear ventilation grilles.
- The ambient temperature is too high.
- ▶ Solution: (see 1.2) .
- The appliance was opened too frequently or for too long.
- ▶ Wait until the appliance reaches the required temperature itself. If not, contact the customer service. (see Maintenance).
- Too much fresh food was placed inside without SuperFrost.
- ▶ Solution: (see 5.6.4)
- The temperature is incorrectly set.

- ▶ Set to a colder temperature and check after 24 h.
- The appliance is too close to a heat source.
- ▶ Solution: (see Putting into operation).

The interior light is not on.

- The appliance is not switched on.
- ▶ Switch on the appliance.
- The door was open longer than 15 min.
- ▶ The interior light automatically switches off if the door has been open for about 15 min.
- The LED lighting is defective or the cover is damaged:



WARNING

Risk of injury due to electric shock!

Live parts are located under the cover.

- ▶ Have the LED interior light changed or repaired only by the customer service or by specialized personnel trained for the purpose.



WARNING

Danger of injury due to laser radiation, class 1M.

- ▶ Do not look inside when the cover is open.

8 Decommissioning

8.1 Switching off the appliance

- ▶ Press On/Off button *Fig. 3 (3)* for about 2 s.
- ▷ The temperature display is dark.

8.2 Taking the appliance out of service

- ▶ Empty the appliance.
- ▶ Pull out the power plug.
- ▶ Clean the appliance (see 6.2) .



- ▶ Leave the door open to prevent odour.

9 Disposing of the appliance

The appliance contains some reusable materials and should be disposed of properly - not simply with unsorted household refuse. Appliances which are no longer needed must be disposed of in a professional and appropriate way, in accordance with the current local regulations and laws.



When disposing of the appliance, ensure that the refrigeration circuit is not damaged to prevent uncontrolled escape of the refrigerant it contains (data on type plate) and oil.

- ▶ Disable the appliance.
- ▶ Pull out the plug.
- ▶ Cut through the connecting cable.