

Operating instructions

Freezer

GB



171110 **7082544 - 02**

EG/IGS ... 1/3

LIEBHERR

Appliance at a glance

Contents

1	Appliance at a glance	2
1.1	Description of appliance and equipment.....	2
1.2	Range of appliance use.....	2
1.3	Conformity.....	2
1.4	Saving energy.....	3
2	General safety information	3
3	Controls and displays	3
3.1	Operating and control elements.....	3
3.2	Temperature display.....	3
4	Putting into operation	3
4.1	Transporting the appliance.....	3
4.2	Installing the appliance.....	4
4.3	Disposing of packaging.....	4
4.4	Connecting the appliance.....	4
4.5	Switching on the appliance.....	4
5	Control	4
5.1	Temperature alarm.....	4
5.2	Freezing food.....	5
5.3	Thawing food.....	5
5.4	Setting the temperature.....	5
5.5	SuperFrost.....	5
5.6	Drawers.....	5
5.7	Shelves.....	5
5.8	VarioSpace.....	6
5.9	Information system.....	6
5.10	Cold storage accumulators.....	6
6	Maintenance	6
6.1	Manual defrosting.....	6
6.2	Cleaning the appliance.....	6
6.3	Customer service.....	7
7	Malfunction	7
8	Decommissioning	7
8.1	Switching off the appliance.....	7
8.2	Taking the appliance out of service.....	7
9	Disposing of the appliance	8

The manufacturer works constantly on the further development of all the types and models. Therefore please understand that we have to reserve the right to make design, equipment and technical modifications.

To get to know all the benefits of your new appliance, please read the information contained in these instructions carefully.

The instructions apply to several models. Differences may occur. Text relating only to specific appliances is marked with an asterisk (*).

Instructions for action are marked with a ►, the results of action are marked with a ▢.

1 Appliance at a glance

1.1 Description of appliance and equipment

Note

► Shelves, drawers and baskets are arranged for optimum energy efficiency on delivery.

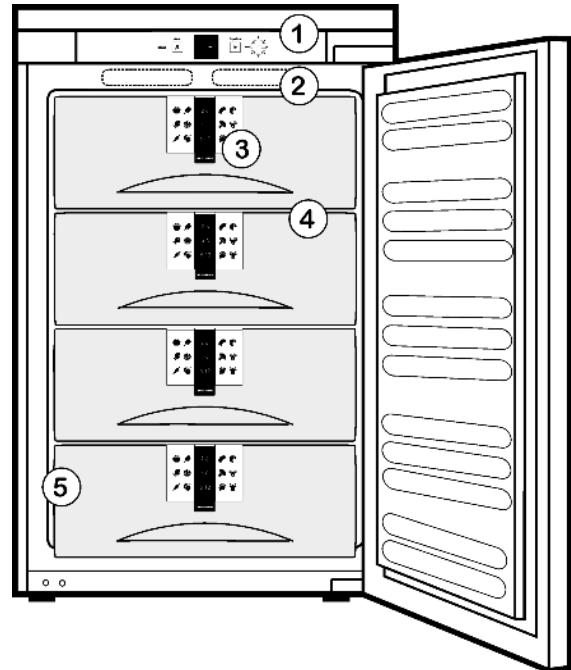

Fig. 1

- | | |
|------------------------------------|----------------|
| (1) Operating and control elements | (4) VarioSpace |
| (2) Cold storage accumulators* | (5) Type plate |
| (3) Information system | |

1.2 Range of appliance use

The appliance is suitable solely for cooling food in a domestic environment or similar. This includes use in, for example

- in staff kitchenettes, bed and breakfast establishments,
- by guests in country homes, hotels, motels and other forms of accommodation,
- in catering and similar services in the wholesale trade

Use the appliance solely as is customary within a domestic environment. All other types of use are inadmissible. The appliance is not suitable for storing and cooling medicines, blood plasma, laboratory preparations or similar substances and products covered by the 2007/47/EC Medical Devices Directive. Misuse of the appliance can result in the stored products suffering harm or perishing. Furthermore, the appliance is not suitable for operation in potentially explosive atmospheres.

The appliance is set to operate within specific ambient temperature limits according to its climate rating. The correct climate rating for your appliance is indicated on the type plate.

Note

► Compliance with the ambient temperatures indicated is required, otherwise the cooling performance is reduced.

Climate rating	for ambient temperatures
SN, N	up to 32 °C
ST	up to 38 °C
T	up to 43 °C

The appliance will function properly in ambient temperatures of down to 5 °C.

1.3 Conformity

The refrigerant circuit has been tested for leaks. When installed, this appliance complies with the relevant safety provisions and EC directives 2006/95/EC and 2004/108/EC.

1.4 Saving energy

- Always ensure good ventilation. Do not cover ventilation openings or grille.
- Do not place appliance in areas of direct sunlight or next to a stove, heater or similar object.
- The energy consumption depends on the installation conditions, e.g. the ambient temperature (see 1.2).
- Keep the time the appliance is open to a minimum.
- The lower the temperature setting, the higher the power consumption.
- Store food logically. (see Appliance at a glance).
- Ensure that all food is well packed and covered for storage. This will prevent frost from forming.
- Remove food as needed in order that it does not warm too much.*
- First cool warm food to room temperature before storing it.
- If there is a thick layer of frost in the appliance: defrost the appliance.

2 General safety information

Danger for the user:

- This appliance is not designed for persons (including children) with physical, sensory or mental impairment or persons not having sufficient experience and knowledge, unless they are instructed in the use of the appliance and are initially supervised by a person responsible for their safety. Keep children under supervision to ensure they do not play with the appliance.
- In case of a fault, pull out the mains plug (not by pulling the connecting cable) or switch off the fuse.
- Have any repairs to or intervention in the appliance, and any change of the mains power cable, carried out by the customer service only or by other specialised personnel trained for the purpose.
- When disconnecting the appliance from the supply, always take hold of the plug. Do not pull the cable.
- Install and connect the appliance only as instructed.
- Please keep these instructions in a safe place and pass them on to any subsequent owners.

Fire hazard:

- The refrigerant R 600a is environmentally friendly but flammable. Escaping refrigerant may ignite.
 - Do not damage the refrigerant circuit pipes.
 - Do not allow naked flames or ignition sources to enter the appliance.
 - Do not use any electrical appliances in the interior (e.g. steam cleaners, heaters, ice cream maker etc.).
 - If refrigerant escapes: eliminate naked flames or sources of ignition from the vicinity. Pull out the power plug. Ventilate the area well. Notify customer service.
- Do not store explosives or sprays using combustible propellants such as butane, propane, pentane, etc. in the appliance. Respective spray cans can be identified by reference to the contents printed on the can or by a flame symbol. Gases possibly escaping may ignite due to electrical components.
- Only store high-percentage alcohol in tightly sealed, upright containers. Alcohol possibly escaping may ignite due to electrical components.

Danger of tipping and falling:

- Do not misuse the plinth, drawers, doors etc. as a step or for support. This applies particularly to children.

Danger of food poisoning:

- Do not consume food which has been stored too long.

Danger of frostbite, numbness and pain:

- Avoid lasting skin contact with cold surfaces or refrigerated/frozen food or take protective steps, e.g. wear gloves. Do

not consume ice cream, water ice or ice cubes immediately and do not consume them too cold.

Please observe the specific information in the other sections:

	DANGER	identifies a situation involving direct danger which, if not obviated, may result in death or severe bodily injury.
	WARNING	identifies a dangerous situation which, if not obviated, may result in death or severe bodily injury.
	CAUTION	identifies a dangerous situation which, if not obviated, may result in minor or medium bodily injury.
	NOTICE	identifies a dangerous situation which, if not obviated, may result in damage to property.
	Note	identifies useful information and tips.

GB

3 Controls and displays

3.1 Operating and control elements

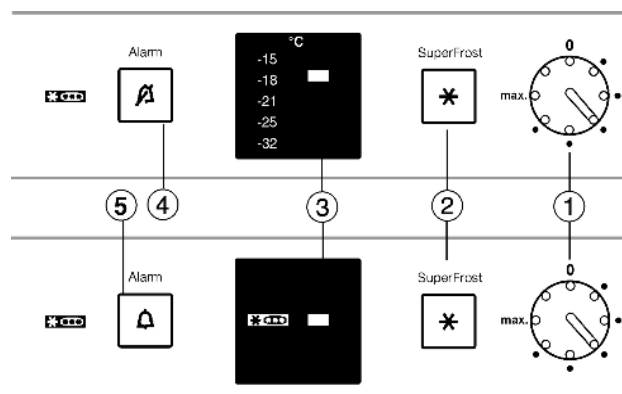

Fig. 2

- (1) Temperature controller
- (2) SuperFrost button
- (3) Temperature display*/ status display*
- (4) Alarm button (luminous display and audible alarm)
- (5) LED alarm (luminous display)

3.2 Temperature display*

The following are displayed in normal operation:

- the set freezing temperature

4 Putting into operation

4.1 Transporting the appliance



CAUTION

Risk of injury and danger of damage as a result of incorrect transport!

- ▶ Transport the appliance in a packed condition.
- ▶ Transport the appliance upright.
- ▶ Do not transport the appliance without assistance.

Control

4.2 Installing the appliance

In the event that the appliance is damaged, contact the supplier immediately before connecting to the mains.

The floor at the site must be flat and level.

Do not install the appliance in a location where it is exposed to direct radiation of the sun, next to a cooker, heater and similar.

Do not install the appliance without assistance.

Standard EN 378 specifies that the room in which you install your appliance must have a volume of 1 m² per 8 g of R 600a refrigerant used in the appliance. If the room in which the appliance is installed is too small, a flammable gas-air mixture may form in the event of a leakage in the refrigeration circuit. The quantity of refrigerant used in your appliance is indicated on the type plate on the inside of the appliance.

Fit the appliance in stable kitchen units only.

The following ventilation gaps must be observed:

- The depth of the ventilation channel at the rear of the unit must be at least 38 mm.
- There must be a ventilation space of at least 200 cm² in the plinth and at the top of the unit.
- Basically the principle applies: the larger the ventilation space, the more energy-saving the appliance is in operation.



WARNING

Fire hazard due to dampness!

If live parts or the mains lead become damp this may cause short circuits.

- ▶ The appliance is designed for use in enclosed areas. Do not operate the appliance outdoors or in areas where it is exposed to splash water or damp conditions.



WARNING

Fire hazard due to refrigerant!

The refrigerant R 600a is environmentally friendly but flammable. Escaping refrigerant may ignite.

- ▶ Do not damage the piping of the refrigeration circuit.



WARNING

Fire hazard and danger of damage!

- ▶ Do not place appliances emitting heat e.g. microwaves, toasters etc. on the appliance!

- ▶ Detach the connecting cable from the rear of the appliance, removing the cable holder at the same time because otherwise there will be vibratory noise!

After installation:

- ▶ Remove all transit supports.
- ▶ Dispose of packaging material (see 4.3) .

Note

- ▶ Clean the appliance (see 6.2) .

If the appliance is installed in a very damp environment, condensate may form on the outside of the appliance.

- ▶ Always see to good ventilation at the installation site.

4.3 Disposing of packaging



WARNING

Danger of suffocation due to packing material and plastic film!

- ▶ Do not allow children to play with packing material.

The packaging is made of recyclable materials:

- corrugated board/cardboard
- expanded polystyrene parts
- polythene bags and sheets
- polypropylene straps
- nailed wooden frame with polyethylene panel*

- ▶ Take the packaging material to an official collecting point.



4.4 Connecting the appliance

NOTICE

Risk of damage to the electronic control system!

- ▶ Do not use stand-alone inverters (conversion of d.c. to a.c./ three-phase) or energy saving plugs.



WARNING

Fire and overheating hazard!

- ▶ Do not use extension cables or multiple socket outlets.

The type of current (alternating current) and voltage at the installation site have to conform with the data on the type plate (see Appliance at a glance).

Connect the appliance only with a properly installed socket outlet with earthing contact. The socket outlet must be fused with 10 A or higher.



- ▶ Check the electrical connection.
- ▶ Plug in the power plug.

4.5 Switching on the appliance

Put the appliance into operation about 4 hours before first loading food to be frozen.

The food for freezing should be placed inside the appliance only when the Alarm LED display has gone out.

- ▶ Turn the temperature control *Fig. 2 (1)* with a coin to the right.
- ▷ The temperature display lights up.*
- ▷ The Alarm LED display shines.
- When the Alarm LED display no longer shines:
 - ▶ start freezing .

5 Control

5.1 Temperature alarm

The audible alarm sounds if the freezer temperature is not cold enough.*

The red Alarm LED display flashes. It shines after the Alarm* button has been pressed.

The cause of the temperature being too high may be:

- warm fresh food was placed inside
- too much warm ambient air flowed in when rearranging and removing food
- power failure for some time
- the appliance is faulty

The audible warning signal is automatically silenced and the Alarm LED display goes out when the temperature is sufficiently cold again.

If the alarm status persists: (see Malfunction).

Note

Food may be spoilt if the temperature is not cold enough.

- ▶ Check the quality of the food. Do not consume spoiled food.

5.1.1 Muting the temperature alarm*

The audible alarm can be muted. When the temperature is sufficiently cold again, the alarm function is active again.

- ▶ Press alarm button *Fig. 2 (4)*.
- ▷ The audible alarm is silenced.

5.2 Freezing food

The rating plate indicates the maximum quantity of fresh food you can freeze within 24 hours (see Appliance at a glance) under "Freezing capacity ... kg/24h".

The maximum load of frozen food for the drawers is 25 kg each and for the shelves 35 kg each.

A vacuum is generated after the door is closed. After closing the door, wait for about 1 minute and then it opens more easily.



CAUTION

Risk of injury due to broken glass!

Bottles and cans containing drinks may burst when being frozen. This applies particularly to sparkling drinks.

- ▶ Do not freeze bottles and cans containing drinks!

In order that the food is rapidly frozen through to the core, do not exceed the following quantities per pack:

- Fruit, vegetables up to 1 kg
- Meat up to 2.5 kg
- ▶ Pack the food in portions in freezer bags, reusable plastic, metal or aluminium containers.

5.3 Thawing food

- at room temperature
- in a microwave oven
- in a conventional or fan oven
- ▶ Food once thawed should be re-frozen only in exceptional cases.

5.4 Setting the temperature

The temperature can be set between the first point (warmest temperature, lowest refrigerating capacity) and max. (coldest temperature, highest refrigerating capacity), the recommended temperature is -18 °C i.e. the 3rd point.

- ▶ Turn the temperature control *Fig. 2 (1)* with a coin until the temperature wanted lights up in the temperature display.*

-or-

- ▶ Turn the temperature *Fig. 2 (1)* control to the 3rd point.

The temperature is dependent on the following factors:

- the frequency of door opening
- the room temperature of the installation site
- the type, temperature and quantity of frozen food

- ▶ You may have to readjust the temperature, depending on the temperature wanted.

if the freezer is relatively empty:

- ▶ readjust temperature after 6 h.

if the freezer is full:

- ▶ readjust temperature after 24 h.

The temperature can be set slightly colder within a temperature range, e. g. -15 °C to -18 °C or between two control settings.

- ▶ If required, slowly turn the temperature control further.
- ▷ The lit bar of the temperature range, e. g. -18 °C flashes briefly. The temperature within the temperature range was set colder.*

5.5 SuperFrost

With this function you can freeze fresh food quickly through to the core. The appliance operates with maximum refrigeration.

The noise of the refrigeration unit may be temporarily louder as a result.

In addition, frozen food already in storage is given a "cold reserve". The food stays frozen longer as a result when you defrost the appliance.

The maximum amount of fresh food which can be frozen in 24 h is indicated on the type plate under "freezing capacity ... kg/24h". This amount varies according to the model and climate rating.

You do not have to activate SuperFrost in the following cases:

- when placing frozen food in the freezer
- when freezing up to about 2 kg fresh food daily

5.5.1 Freezing with SuperFrost

- ▶ Briefly press the SuperFrost button *Fig. 2 (2)*.
- ▷ The SuperFrost button shines.
- ▷ The freezer temperature drops, the appliance operates with the maximum refrigerating capacity.
- In case of a small amount of food to be frozen:
 - ▶ wait about 6 h.
 - ▶ Place the fresh food in the bottom drawers.
- In case of the maximum amount of food to be frozen (see type plate):
 - ▶ wait about 24 h.
 - ▶ Place wrapped food straight onto the shelves and put it into the drawers once it has frozen.
- ▷ SuperFrost is automatically deactivated after about 65 h.
- ▷ The SuperFrost button is dark.
- ▷ The temperature range set for the normal mode shines in the temperature display.*
- ▷ The appliance continues to operate in the energy-saving, normal mode.

5.6 Drawers

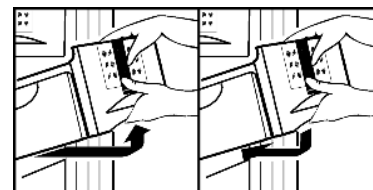

- ▶ To store frozen food directly on the shelves: pull the drawer forwards and lift it out.

5.7 Shelves

- ▶ To remove the shelf: lift up at the front and pull out.
- ▶ To put the shelf back: simply push in as far as it will go.



5.8 VarioSpace

Apart from being able to remove the drawers, you can also remove the shelves, creating space for large items of frozen food. Poultry, meat, large pieces of game and high bakery products can be frozen in one piece and prepared.

- ▶ The maximum load of frozen food for the drawers is 25 kg each and for the shelves 35 kg each.

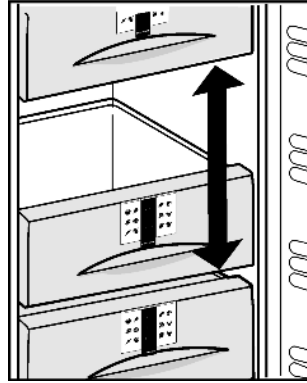

5.9 Information system

①		2-6		④
②		4-8		⑤
③		6-12		⑥

Fig. 3

- | | |
|---------------------------------|------------------------|
| (1) Ready-made meals, ice cream | (4) Sausages, bread |
| (2) Pork, fish | (5) Game, mushrooms |
| (3) Fruit, vegetables | (6) Poultry, beef/veal |

The figures indicate the storage time in months for several types of frozen food in each case. Storage times given are guide times.

5.10 Cold storage accumulators*

The cold storage accumulators prevent the temperature from rising too fast in the event of power failure.

5.10.1 Using cold storage accumulators*

- ▶ Freeze and store the cold storage accumulators in the ceiling of the freezer compartment (appliances without No-Frost module).

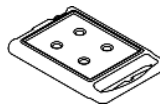

With the top drawer removed:

- ▶ to insert cold storage accumulators: slide cold storage accumulator into the top back of the freezer compartment ceiling and snap into place at the front.

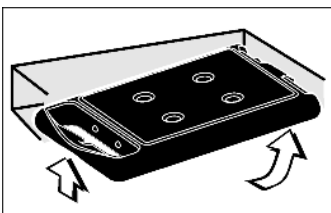

With the top drawer removed:

- ▶ to remove cold storage accumulators: take hold of the cold storage accumulator at the side and press it down for removal.

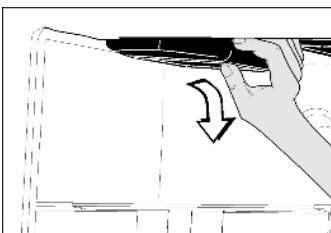

6 Maintenance

6.1 Manual defrosting

After a long period of operation, a layer of frost or ice can build up inside the appliance.

The layer of frost or ice builds up faster if the appliance is opened often or if the food is warm when placed inside. However, a thick layer of ice will increase the appliance's energy consumption. You should therefore defrost the appliance regularly.



CAUTION

Risk of injury and damage as a result of hot steam!

- ▶ Do not use electric heaters or steam cleaners, naked flames or defrosting sprays for defrosting.
- ▶ Do not remove ice using sharp instruments.

- ▶ Switch on SuperFrost one day before defrosting.
- ▷ The frozen goods are provided with a "cold reserve".
- ▶ Switch off the appliance.
- ▷ The temperature display goes out.*
- ▶ Pull out the power plug or switch off the fuse.
- ▶ Place cold storage accumulators on top of the frozen food.*
- ▶ If possible, put the frozen goods in the freezer drawer, wrapped in newspaper or a blanket, and store in a cool place.
- ▶ Place a pan with hot, not boiling water on a middle shelf.

-or-

- ▶ Half-fill the two lower drawers with lukewarm water and put them in the appliance.

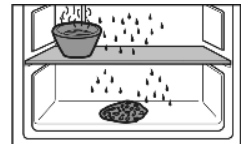

- ▷ Defrosting is speeded up.
- ▷ Defrost water is collected in the drawers.
- ▶ Leave the door of the appliance open while defrosting.
- ▶ Remove detached pieces of ice.
- ▶ Pay attention that the defrost water does not run into the kitchen unit.
- ▶ If necessary, pick up defrost water several times, using a sponge or cloth.
- ▶ Clean the appliance (see 6.2) and rub dry.

6.2 Cleaning the appliance

Before cleaning:



CAUTION

Risk of injury and damage as a result of hot steam! Hot steam may damage the surfaces and cause burns.

- ▶ Do not use any steam cleaners!

NOTICE

Incorrect cleaning damages the appliance!

- ▶ Do not use cleaning agents in concentrated form.
- ▶ Do not use any scouring or abrasive sponges or steel wool.
- ▶ Do not use any cleaning agents containing sand, chloride, chemicals or acid.
- ▶ Do not use chemical solvents.
- ▶ Do not damage or remove the type plate on the inside of the appliance. It is important for the customer service.
- ▶ Do not pull off, bend or damage cables or other components.
- ▶ Do not allow any cleaning water to enter the drain channel, ventilation grille or electrical parts.

- ▶ Empty the appliance.
- ▶ Pull out the plug.
- Use soft cleaning cloths and a multi-purpose cleaning agent with neutral pH value.
- Only use food compatible cleaning and care agents on the inside of the appliance.
- ▶ Regularly clean ventilation grilles.
- ▷ Dust deposits increase energy consumption.



Interior:

- ▶ Clean the plastic surfaces, outside and inside, by hand using lukewarm water and a little washing-up liquid.

Items of equipment:

- ▶ Clean items of equipment by hand with lukewarm water and a little washing-up liquid.

After cleaning:

- ▶ Wipe dry the appliance and items of equipment.
- ▶ Connect the appliance and switch it on again.
- ▶ Switch on SuperFrost (see 5.5).
- When the temperature is sufficiently cold:
- ▶ Put the food back inside.

6.3 Customer service

First check whether you can correct the fault yourself by reference to the list (see Malfuction). If this is not the case, please contact the customer service whose address is given in the enclosed customer service list.



WARNING

Risk of injury if repair work is not carried out professionally!

- ▶ Have any repairs and action - not expressly specified - on the appliance and mains cable carried out by service personnel only. (see Maintenance)

- ▶ Read the appliance designation *Fig. 4 (1)*, service No. *Fig. 4 (2)* and serial No. *Fig. 4 (3)* off the type plate located inside the appliance on the left-hand side.

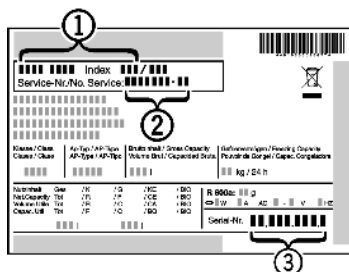

Fig. 4

- ▶ Notify the customer service, specifying the fault, appliance designation *Fig. 4 (1)*, service No. *Fig. 4 (2)* and serial No. *Fig. 4 (3)*.
- ▷ This will help us to provide you with a faster and more accurate service.
- ▶ Keep the appliance closed until the customer service arrives.
- ▷ The food will stay cool longer.
- ▶ Pull out the mains plug (not by pulling the connecting cable) or switch off the fuse.

7 Malfuction

Your appliance is designed and manufactured for a long life span and reliable operation. If a malfuction nonetheless occurs during operation, check whether it is due to a handling error. In this case you will have to be charged for the costs incurred, even during the warranty period. You may be able to rectify the following faults yourself:

Appliance does not work.

- The appliance is not switched on.
- ▶ Switch on the appliance.
- The power plug is not properly inserted in the wall socket.

- ▶ Check power plug.
- The fuse of the wall socket is not in order.

- ▶ Check fuse.

The compressor runs for a long time.

- SuperFrost is activated.
- ▶ The compressor runs for longer in order to rapidly cool the food. This is normal.

Excessive noise.

- Speed-controlled* compressors may produce varying running noise due to different speed steps.
- ▶ The sound is normal.

A bubbling and gurgling noise.

- This noise comes from the refrigerant flowing in the refrigeration circuit.
- ▶ The sound is normal.

A quiet clicking noise.

- The noise is produced whenever the refrigeration unit (motor) automatically switches on or off.
- ▶ The sound is normal.

A hum. It is briefly a little louder when the refrigeration unit (the motor) switches on.

- The refrigeration increases automatically when the SuperFrost, function is activated, fresh food has just been placed in the appliance or the door has been left open for a while.
- ▶ The sound is normal.
- The ambient temperature is too high.
- ▶ Solution: (see 1.2)

The SuperFrost button flashes together with the temperature display.

- There is a fault.
- ▶ Contact the customer service. (see Maintenance).

The temperature is not cold enough.

- The door of the appliance is not properly closed.
- ▶ Close the door of the appliance.
- Insufficient ventilation.
- ▶ Clear ventilation grilles.
- The ambient temperature is too high.
- ▶ Solution: (see 1.2).
- The appliance was opened too frequently or for too long.
- ▶ Wait until the appliance reaches the required temperature itself. If not, contact the customer service. (see Maintenance).
- Too much fresh food was placed inside without SuperFrost.
- ▶ Solution: (see 5.5)
- The appliance is too close to a heat source.
- ▶ Solution: (see Putting into operation).
- The appliance was not inserted properly into the recess.
- ▶ Check whether the appliance was inserted correctly and the door closes properly.

8 Decommissioning

8.1 Switching off the appliance

- ▶ Using a coin, turn the temperature control *Fig. 2 (1)* to 0.
- ▷ The temperature display is dark.*

8.2 Taking the appliance out of service

- ▶ Empty the appliance.
- ▶ Pull out the power plug.
- ▶ Clean the appliance (see 6.2).



- ▶ Leave the door open to prevent odour.

9 Disposing of the appliance

The appliance contains some reusable materials and should be disposed of properly - not simply with unsorted household refuse. Appliances which are no longer needed must be disposed of in a professional and appropriate way, in accordance with the current local regulations and laws.



When disposing of the appliance, ensure that the refrigeration circuit is not damaged to prevent uncontrolled escape of the refrigerant it contains (data on type plate) and oil.

- ▶ Disable the appliance.
- ▶ Pull out the plug.
- ▶ Cut through the connecting cable.