

Operating and installation instructions

Combined fridge-freezer

GB

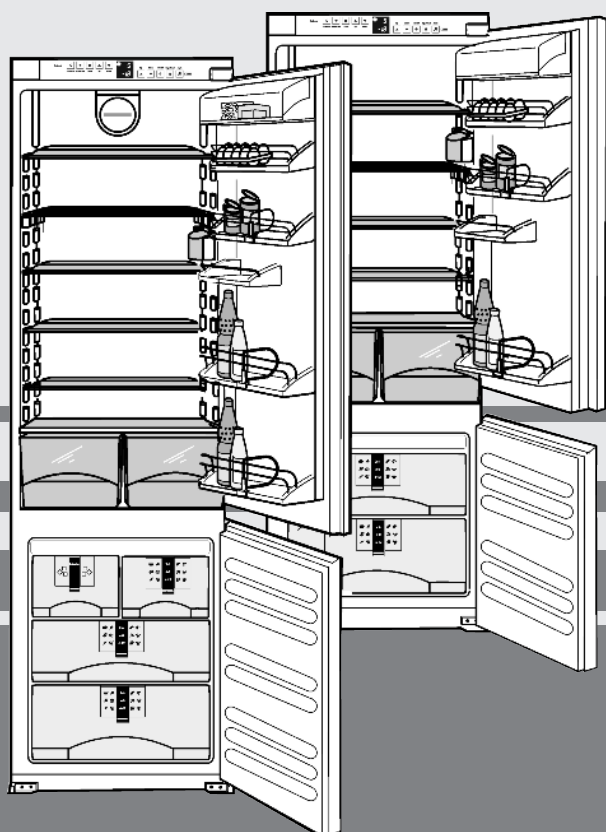

25/08 **7082532 - 01**

IC/ICN/SICN ... 6

LIEBHERR

Appliance at a glance

Contents

1 Appliance at a glance	2
1.1 Range of appliance use.....	2
1.2 Conformity.....	2
1.3 Appliance and equipment overview.....	2
1.4 Net@Home.....	3
2 General safety information	3
3 Controls and displays	3
3.1 Operating and control elements.....	3
3.2 Temperature display.....	3
4 Putting into operation	3
4.1 Changing the door hinges.....	3
4.2 Installation.....	4
4.3 Transporting the appliance.....	8
4.4 Installing the appliance.....	8
4.5 Disposing of packaging.....	8
4.6 Connecting the appliance.....	8
4.7 Switching on the appliance.....	9
5 Control	9
5.1 Saving energy.....	9
5.2 Brightness of the temperature display.....	9
5.3 Child proofing.....	9
5.4 Door alarm.....	9
5.5 Temperature alarm.....	9
5.6 Refrigerator compartment.....	10
5.7 Freezer compartment.....	11
6 Maintenance	13
6.1 Defrosting with NoFrost.....	13
6.2 Manual defrosting.....	13
6.3 Cleaning the appliance.....	13
6.4 Cleaning the IceMaker.....	14
6.5 Customer service.....	14
7 Malfunction	14
8 Decommissioning	15
8.1 Switching off the appliance.....	15
8.2 Taking the appliance out of service.....	15
9 Disposing of the appliance	15

The manufacturer works constantly on the further development of all the types and models. Therefore please understand that we have to reserve the right to make design, equipment and technical modifications.

To get to know all the benefits of your new appliance, please read the information contained in these instructions carefully.

Instructions for action are marked with a ►, the results of action are marked with a ▷.

1 Appliance at a glance

1.1 Range of appliance use

The appliance is designed for cooling food, for freezing and storing food and for making ice.

The appliance was designed for household use. It is not intended for commercial use, in particular it is not meant for laboratory purposes and the like. There is the danger of malfunction.

The appliance is set to operate within specific ambient temperature limits according to its climate rating. The correct climate rating for your appliance is indicated on the type plate.

Note

► Compliance with the ambient temperatures indicated is required, otherwise the cooling performance is reduced.

Climate rating	for ambient temperatures of
SN	10 °C to 32 °C
N	16 °C to 32 °C
ST	16 °C to 38 °C
T	16 °C to 43 °C

1.2 Conformity

The refrigerant circuit has been tested for leaks. When installed, this appliance complies with the relevant safety provisions and EC directives 2006/95/EC and 2004/108/EC.

1.3 Appliance and equipment overview

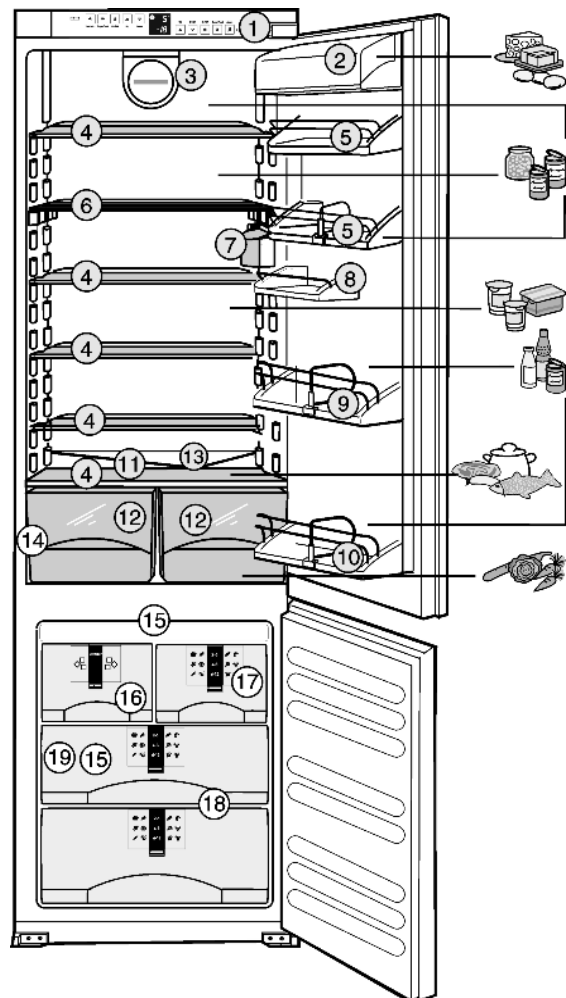

Fig. 1

- | | |
|------------------------------------|--------------------------------|
| (1) Operating and control elements | (11) Coldest zone |
| (2) Butter and cheese compartment | (12) Vegetable bin |
| (3) Fan | (13) Drain hole |
| (4) Shelf, relocatable | (14) Type plate |
| (5) Preserves rack | (15) Cold storage accumulator* |
| (6) Shelf, sectioned | (16) IceMaker* |
| (7) Interior light | (17) Information system* |
| (8) Egg tray* | (18) VarioSpace* |
| (9) Storage rack | (19) Freezer tray* |
| (10) Storage rack for tall bottles | |

1.4 Net@Home

The appliance can be provided with the retrofit modules for the HomeDialog system or the serial interface (RS 232), depending on model and equipment. The modules are available from your specialist dealer.

You will find more information on the internet at www.liebherr.com.



2 General safety information

Danger for the user:

- This appliance is not designed for persons (including children) with physical, sensory or mental impairment or persons not having sufficient experience and knowledge, unless they are instructed in the use of the appliance and are initially supervised by a person responsible for their safety. Keep children under supervision to ensure they do not play with the appliance.
- In case of a fault, pull out the mains plug (not by pulling the connecting cable) or switch off the fuse.
- Have any repairs to or intervention in the appliance, and any change of the mains power cable, carried out by the customer service only or by other specialised personnel trained for the purpose.
- When disconnecting the appliance from the supply, always take hold of the plug. Do not pull the cable.
- Install and connect the appliance only as instructed.
- Please keep these instructions in a safe place and pass them on to any subsequent owners.

Fire hazard:

- The refrigerant R 600a is environmentally friendly but flammable. Escaping refrigerant may ignite.
 - Do not damage the refrigerant circuit pipes.
 - Do not allow naked flames or ignition sources to enter the appliance.
 - Do not use any electrical appliances in the interior (e.g. steam cleaners, heaters, ice cream maker etc.).
 - If refrigerant escapes: eliminate naked flames or sources of ignition from the vicinity. Pull out the power plug. Ventilate the area well. Notify customer service.
- Do not store explosives or sprays using combustible propellants such as butane, propane, pentane, etc. in the appliance. Respective spray cans can be identified by reference to the contents printed on the can or by a flame symbol. Gases possibly escaping may ignite due to electrical components.
- Only store high-percentage alcohol in tightly sealed, upright containers. Alcohol possibly escaping may ignite due to electrical components.

Danger of tipping and falling:

- Do not misuse the plinth, drawers, doors etc. as a step or for support. This applies particularly to children.

Danger of food poisoning:

- Do not consume food which has been stored too long.

Danger of frostbite, numbness and pain:

- Avoid lasting skin contact with cold surfaces or refrigerated/frozen food or take protective steps, e.g. wear gloves. Do not consume ice cream, water ice or ice cubes immediately and do not consume them too cold.

Please observe the specific information in the other sections:

	DANGER	identifies a situation involving direct danger which, if not obviated, may result in death or severe bodily injury.
--	---------------	---

	WARNING	identifies a dangerous situation which, if not obviated, may result in death or severe bodily injury.
	CAUTION	identifies a dangerous situation which, if not obviated, may result in minor or medium bodily injury.
	NOTICE	identifies a dangerous situation which, if not obviated, may result in damage to property.
	Note	identifies useful information and tips.

3 Controls and displays

3.1 Operating and control elements

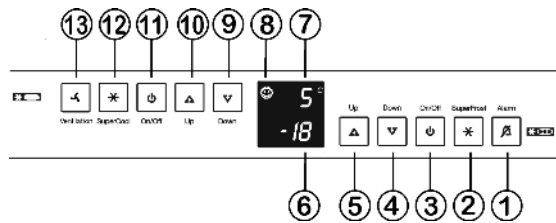

Fig. 2

- (1) Alarm button
- (2) SuperFrost button
- (3) On/Off button freezer compartment
- (4) Down setting button freezer compartment
- (5) Up setting button freezer compartment
- (6) Temperature display freezer compartment
- (7) Temperature display refrigerator compartment
- (8) Child lock symbol
- (9) Down setting button refrigerator compartment
- (10) Up setting button refrigerator compartment
- (11) On/Off button refrigerator compartment
- (12) SuperCool button
- (13) Fan button

3.2 Temperature display

The following are displayed in normal operation:

- the warmest freezing temperature
 - the average cooling temperature
- The freezer compartment temperature display flashes:
- the temperature setting is being changed
 - after switch-on the temperature is not yet cold enough
 - the temperature has risen several degrees

Dashes flash in the display:

- the freezer temperature is above 0 °C.

The following displays indicate malfunction. You will find possible causes and corrective action in the section on troubleshooting.

- nR
- F0 to F5

4 Putting into operation

4.1 Changing the door hinges

Make sure the following tools are to hand:

- spanner 13
- cordless screwdriver Torx 15, 20, 25, 30

Slide the appliance 2/3 of the way into the recess.

Pull out the mains plug.

Putting into operation

Open the doors.

4.1.1 To detach the soft stop mechanism



CAUTION

Risk of injury if soft stop contracts!

► Detach with care.

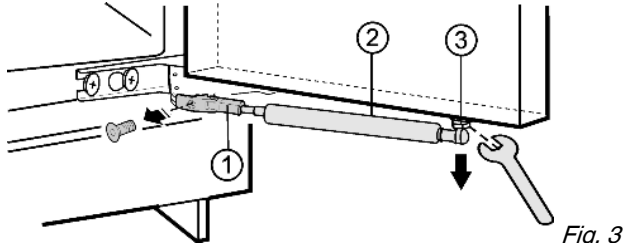

Fig. 3

- Unscrew holder Fig. 3 (1).
- Unscrew the ball stud Fig. 3 (3) together with the soft stop mechanism Fig. 3 (2) from the door and set it aside.

4.1.2 To change the hinges

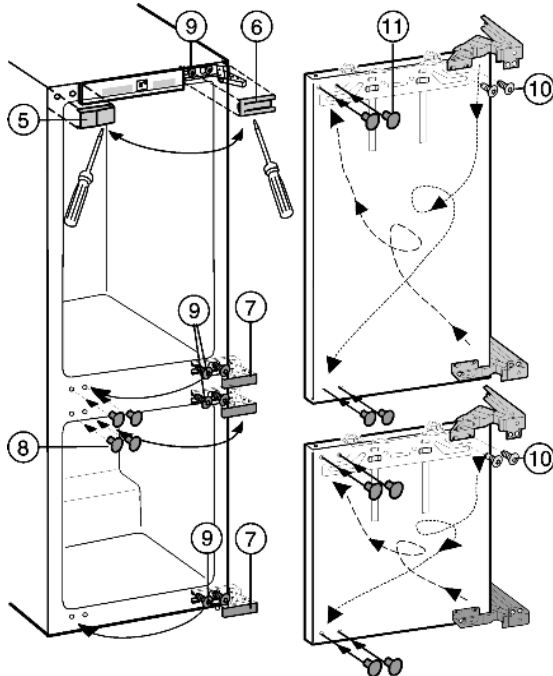

Fig. 4

- Lift off the covers Fig. 4 (5,6,7,8) forwards using a flat-blade screwdriver.
- Loosen the top and bottom screws Fig. 4 (9) on the appliance body, without removing them.
- Pull the doors outwards and detach them.
- Transfer the screws Fig. 4 (9) to the opposite side and screw them in a little.
- Undo the screws Fig. 4 (10) and change over the hinges diagonally.

The screws Fig. 4 (10) are self-tapping: use a cordless screwdriver.

- Screw the hinges tight.
- Place plugs Fig. 4 (11) in the now unused fastening holes.
- Attach the doors to the prefitted screws Fig. 4 (9) and tighten the screws.

4.1.3 Re-fit the soft stop mechanism

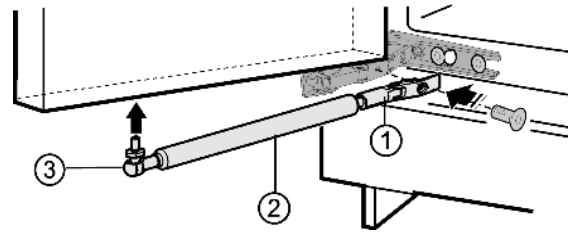

Fig. 5

- Screw on the holder Fig. 5 (1).
- Screw the ball stud Fig. 5 (3) together with the soft stop mechanism Fig. 5 (2) into the fastening hole.
- Re-fit all the covers Fig. 4 (5,6,7,8).

4.2 Installation

All the fasteners accompany the appliance.

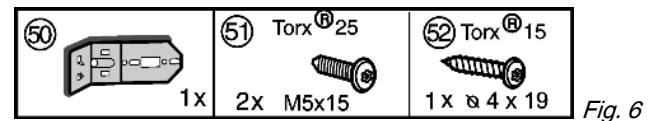

Fig. 6

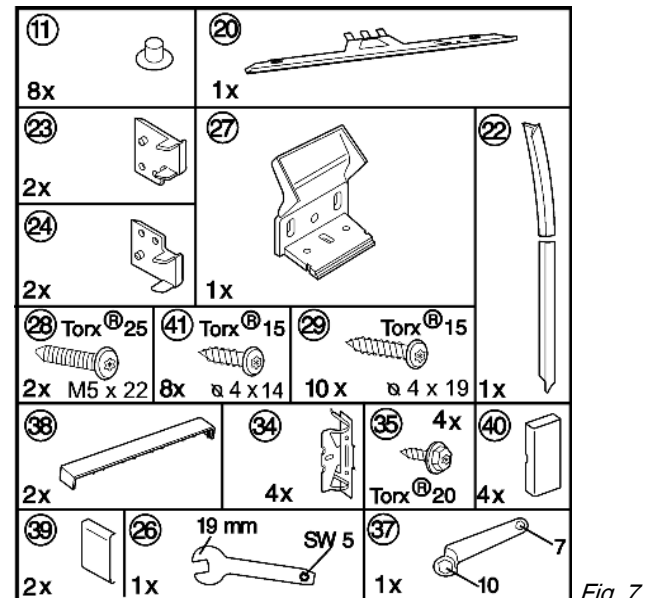

Fig. 7

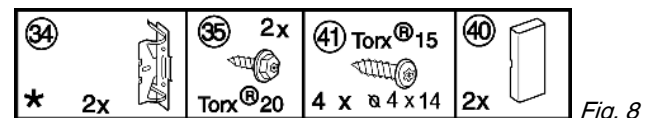

Fig. 8

Ensure that the following tools are to hand:

- cordless screwdriver Torx®15, 20, 25
- spanner 13

The shelf and side walls of the unit must be at right-angles to one another. Align the unit with a spirit level and an angle. If necessary, level out by building up from underneath.

The appliance can also be installed in an ordinary kitchen cabinet. In this case detach the fittings of the unit door and recess. They are no longer needed as the unit door is fitted to the appliance door.

Note

- Before assembling the door of the unit, make sure that the admissible weight of the unit door is not exceeded.
- Otherwise damage to the hinges and resultant malfunction cannot be ruled out.

	Max. weight of unit door	
	Refrigerator compartment door	Freezer compartment door
ICN 30.., SICN 30..	14 kg	12 kg
IC 29..	13 kg	12 kg

Check installation dimensions:

	A	B	C
ICN 30.., SICN 30..	1772 mm - 1778 mm	1769.5 mm	695 mm
IC 29..	1574 mm - 1590 mm	1574,5 mm	549 mm

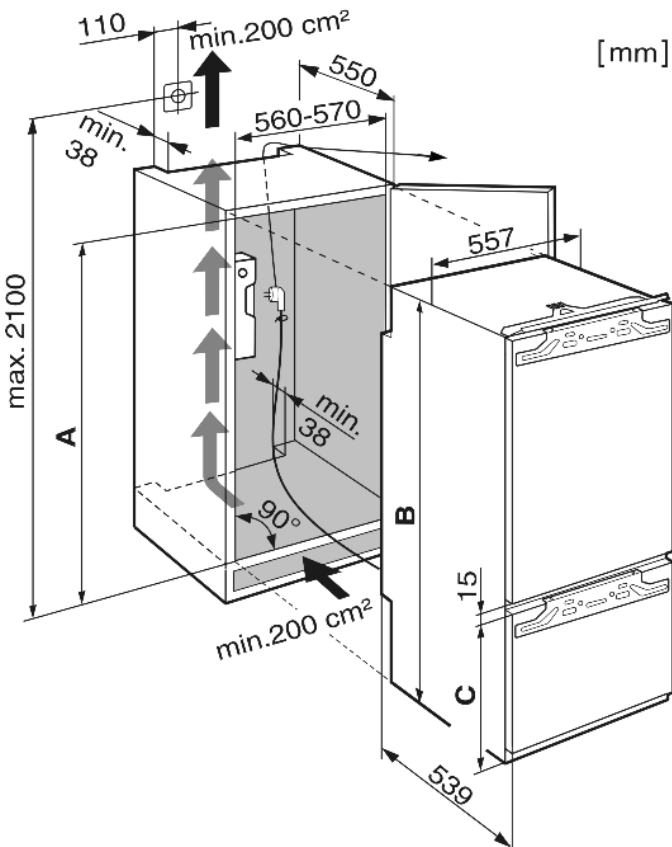

Fig. 9

4.2.1 Assembling appliance

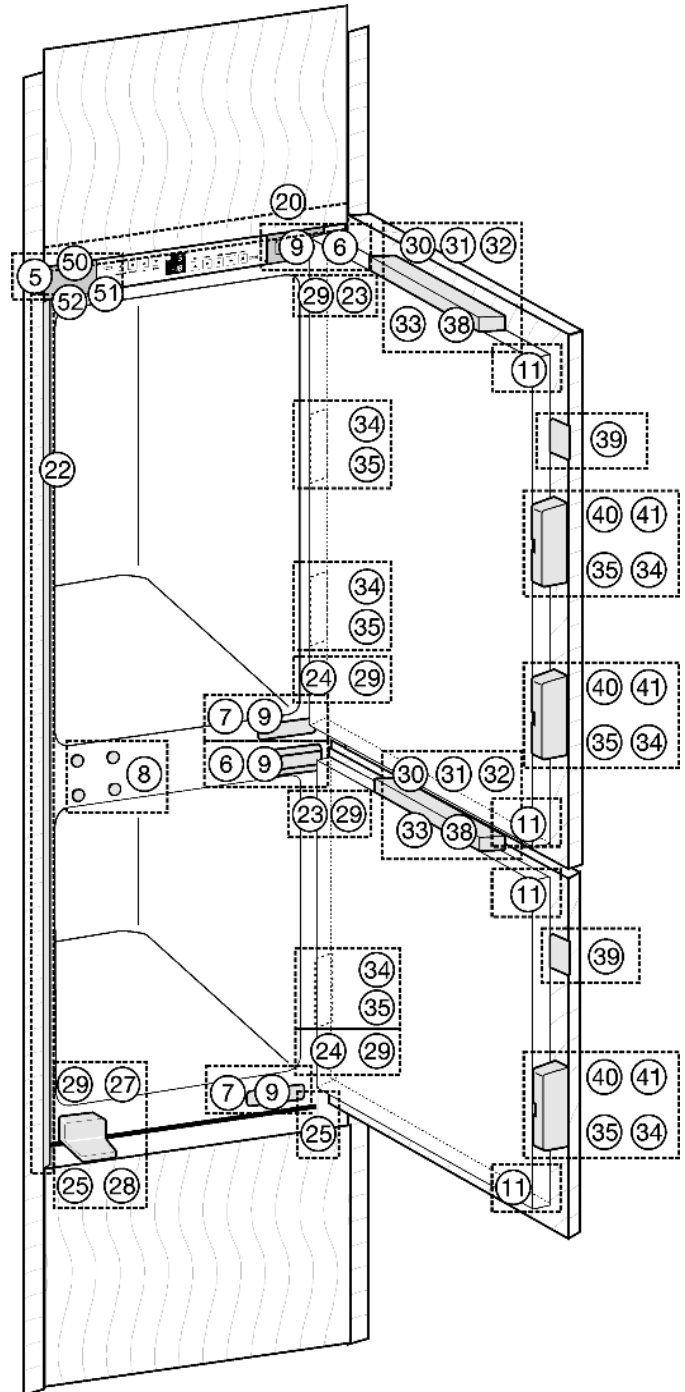

Fig. 10

- ▶ Detach the connecting cable from the back of the appliance, removing the cable holder because otherwise there will be vibratory noise!
- ▶ Lay the connecting cable with the help of a string in such a way that the appliance can be easily connected after fitting.

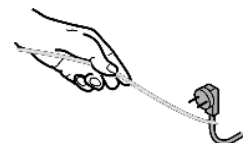

Fig. 11

- For appliances with permanently plumbed in IceMaker:**
- ▶ connect the IceMaker according to the section on water connection.*
- Fehler beim Erfassen! Kette "fixtoother..." unterbrochen.
- ▶ Slide the appliance 2/3 of the way into the recess.
 - ▶ Remove covers Fig. 10 (5,6,7).

Putting into operation

- ▶ Fit the equaliser trim *Fig. 12 (20)* centrally onto the appliance: slide into holding fixture and engage in keyholes.

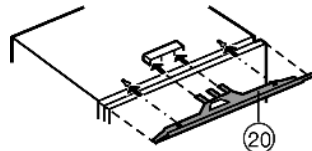

Fig. 12

- ▶ Screw mounting bracket *Fig. 13 (34)* with hexagon screw *Fig. 13 (35)* into the pilot holes in the appliance door.

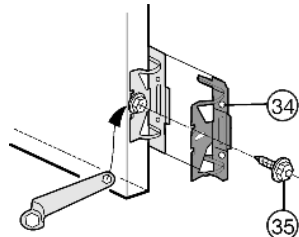

Fig. 13

For 16 mm thick unit walls = 568 mm wide recess:

- ▶ Clip spacer *Fig. 14 (23)* onto the upper hinge and spacer *Fig. 10 (24)* onto the lower hinge.

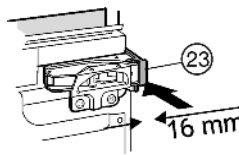
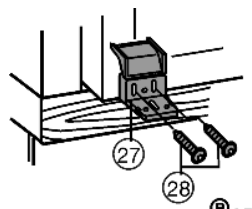

Fig. 14

- ▶ Screw plastic bracket *Fig. 15 (27)* onto the handle side of the appliance with M5 screws *Fig. 15 (28)*.



Torx® 25

Fig. 15

- ▶ Loosely screw *Fig. 16 (51)* the mounting bracket *Fig. 16 (50)* to the appliance through the oblong holes.
- ▷ The bracket can then still be aligned to the wall of the unit.

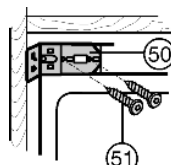

Fig. 16

- ▶ Remove the protective film from the trim *Fig. 17 (22)*. Apply the strip to the bottom edge of the mounting bracket *Fig. 16 (50)* on the side wall of the appliance on the handle side and flush with the front and glue on.
- ▶ If necessary, shorten the trim *Fig. 17 (22)* to the height of the recess.*

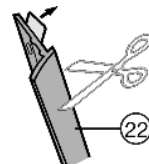

Fig. 17

To slide in and align the appliance:

- ▶ Slide in the appliance.

For 16 mm thick unit walls = 568 mm wide recess:

- ▶ Slide appliance into the recess until the spacers make contact with the side wall of the unit.

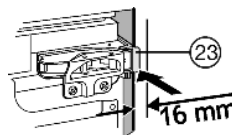

Fig. 18

For 19 mm thick unit walls = 562 mm wide recess:

- ▶ Align the front edges of the hinges so as to be flush with the side wall of the unit.

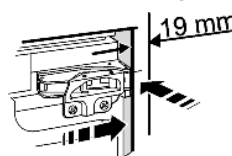

Fig. 19

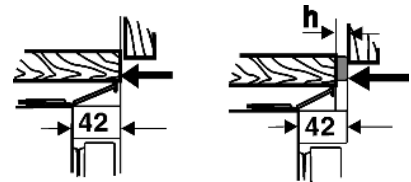

Fig. 20

In case of units with (16 mm and 19 mm) door stop components (knobs, sealing lips etc.):

- ▶ To allow for the extra distance (depth of door stop components): allow the hinges to protrude by the extra distance.

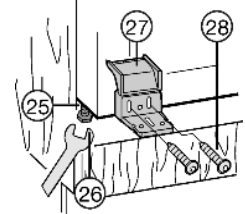

Fig. 21

For units without door stop components:

- ▶ Align the plastic bracket *Fig. 21 (27)* in depth so as to be flush with the front edge of the base of the unit.

For units with door stop components:

- ▶ allow for additional space needed: align plastic bracket *Fig. 21 (27)* parallel to the front edge of the hinge.

For units with set back base:

- ▶ Align plastic bracket *Fig. 21 (27)* in depth so as to be flush with the front edges of the side walls of the unit, even if the bracket projects over the base of the unit as a result.
- ▶ Level the appliance by means of the adjustable feet *Fig. 21 (25)* using the accompanying spanner *Fig. 21 (26)*.

Note

Incorrect installation will lead to malfunction!

If the distance is not kept, the door may not close. This may lead to icing, to condensate forming and to malfunction.

- ▶ Be sure to keep to a spacing of 42 mm all the way round. (Allow for door stop components, such as knobs and sealing lips.)

To secure the appliance in the recess:

- ▶ On both doors fit Spax screws *Fig. 22 (29)* through the plates of the upper and lower hinges.

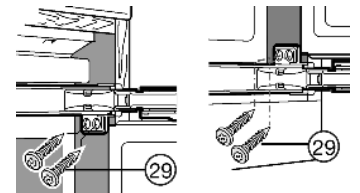

Fig. 22

- ▶ Screw the mounting bracket tight onto the unit wall with Spax screw $\varnothing 4 \times 19$ *Fig. 23 (52)*.

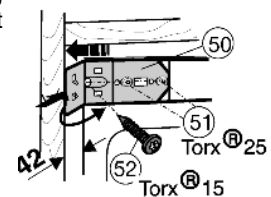

Fig. 23

- ▶ Push the mounting bracket *Fig. 23 (50)* against the wall of the unit and tighten the two M5 screws, Torx 25 *Fig. 23 (51)*.

- ▶ Preassemble by passing a long screw *Fig. 24 (29)* through the oblong hole in the plastic bracket *Fig. 24 (27)*.

- ▶ Fold down the cover of the plastic bracket *Fig. 24 (27)*.

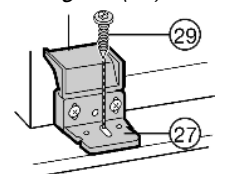

Fig. 24

- ▶ Close the appliance door.

4.2.2 Fitting the unit doors

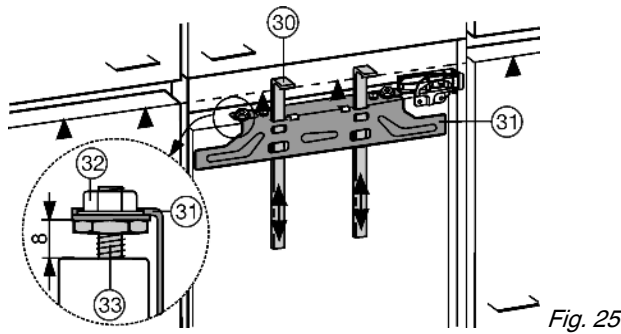

Fig. 25

The fitting aids Fig. 25 (30) are required for both doors. Therefore fit the doors of the units one after the other.

- ▶ Check 8 mm presetting. (Distance between appliance door and lower edge of crosspiece)
- ▶ Raise fitting aids Fig. 25 (30) to unit door height. Lower edge ▲ of fitting aid = upper edge of unit door to be fitted.
- ▶ Unscrew crosspiece Fig. 26 (31) by undoing the locknuts Fig. 25 (32).
- ▶ Attach the crosspiece Fig. 26 (31) to the inside of the unit door using the fitting aids Fig. 26 (30).

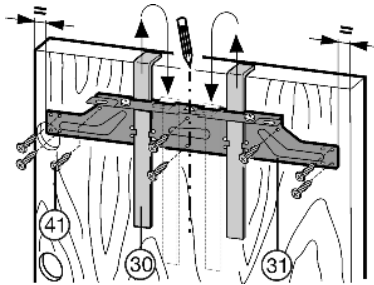

Fig. 26

- ▶ Centre the crosspiece Fig. 26 (31); mark a short centre line on the unit door and put the tip of the arrow on the crosspiece above it.
- ▷ Distances to the outer edge are equal at the left and right.
- For chipboard doors:**
- ▶ fix the crosspiece Fig. 26 (31) with at least 6 screws Fig. 26 (41).
- For frame and panel doors:**
- ▶ fix the crosspiece Fig. 26 (31) with 4 screws Fig. 26 (41) at the edge.
- ▶ Lift out the fitting aids Fig. 26 (30), turn round and insert into the adjacent openings.

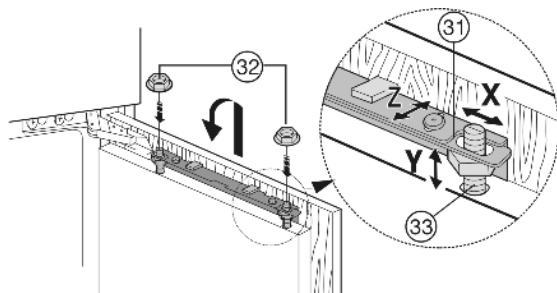

Fig. 27

- ▶ Attach the unit door to the adjusting bolts Fig. 27 (33) and loosely screw the locknuts Fig. 27 (32) onto them.
- ▶ Close the door.
- ▶ Check the gap between the door and the surrounding unit doors.
- ▶ To laterally align the unit door: move the unit door in the X direction.
- ▶ To align the unit door in height and lateral inclination: set the adjusting bolts Fig. 27 (33) with a screwdriver.
- ▷ The unit door is flush and in alignment with the surrounding unit fronts.
- ▶ Tighten counternuts Fig. 27 (32).

Mounting bracket: Fig. 28 (34) Ensure that both metal edges are flush (symbol //):

- ▶ Drill pilot holes in the door of the unit (possibly make preliminary hole with a bradawl).

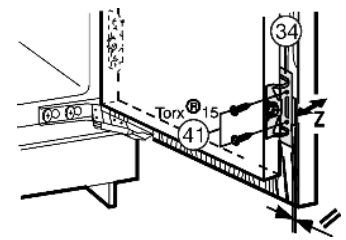

Fig. 28

- ▶ Screw the appliance door to the unit door with screws Fig. 28 (41) passed through the mounting brackets Fig. 28 (34).

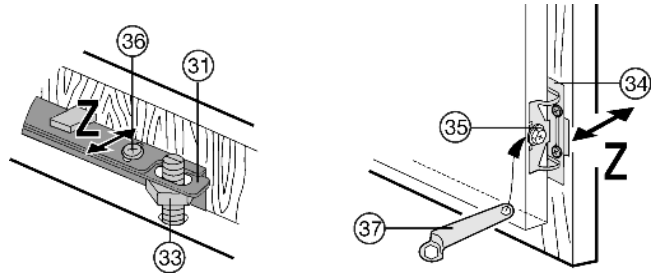
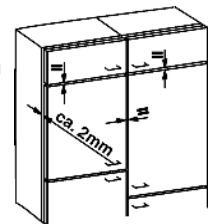

Fig. 29

- ▶ To align the unit door in depth Z: undo top screws Fig. 29 (36), bottom hexagon screws Fig. 29 (35) with accompanying ring spanner Fig. 29 (37), then move the door.
- ▶ Do not allow knobs and sealing lips to contact the door - important for function!
- ▶ Allow an air gap of approx. 2 mm between the unit door and the body of the unit.



For large unit doors:

- ▶ fit a 3rd pair of mounting brackets Fig. 29 (34).
- ▶ Use the holes pre-drilled in the handle area of the appliance door for this purpose.

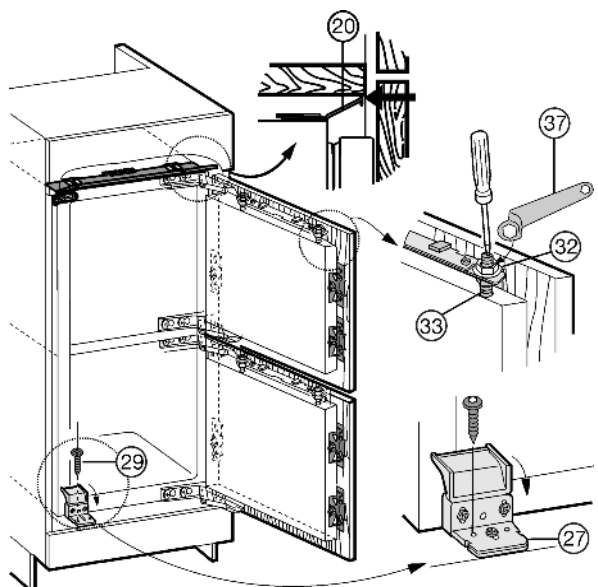
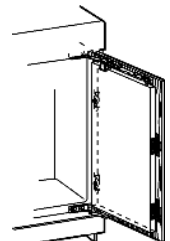

Fig. 30

(32) counternuts (33) adjusting bolts

(37) ring spanner

- ▶ Check the fit of the door and readjust if necessary.

Putting into operation

- ▶ Tighten all screws.
- ▶ Tighten the counternuts *Fig. 30 (32)* with the ring spanner *Fig. 30 (37)* provided, counter-holding the adjusting bolts *Fig. 30 (33)* with a screwdriver.
- ▶ Align the equaliser trim *Fig. 30 (20)* if necessary by moving it parallel to the base of the unit, so that it does not project.
- ▶ Fix the appliance in the round hole at the bottom with the second screw *Fig. 30 (29)* through the plastic bracket *Fig. 30 (27)*.
- ▶ Position upper covers *Fig. 31 (38)* and snap into place.
- ▶ Place lateral covers *Fig. 31 (39)* in position, slide them to the limit, then press, until you hear them snap into place.
- ▶ Attach covers *Fig. 31 (40)* to the side and then draw them forwards with a screwdriver so that they snap into place.

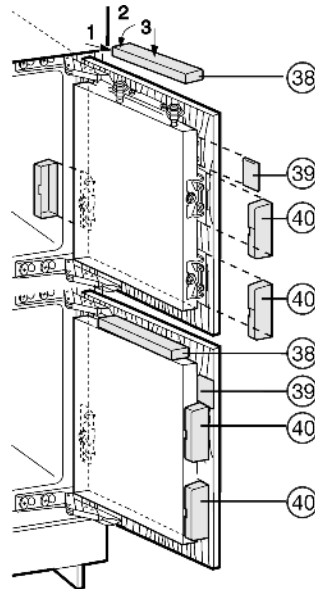

Fig. 31

- ▶ Attach covers *Fig. 10 (5,6,7)*.
- Check the following points to ensure the appliance is fitted properly. Failure to do so may lead to icing, condensate forming and malfunction:
- ▷ The door has to close properly
 - ▷ The unit door must not butt against the unit body
 - ▷ The seal must have a firm fit at the upper corner on the handle side. To check, darken the room, place a torch inside the appliance at the top and close the door. If light shines through, check the assembly.

4.3 Transporting the appliance



CAUTION

Risk of injury and danger of damage as a result of incorrect transport!

- ▶ Transport the appliance in a packed condition.
- ▶ Transport the appliance upright.
- ▶ Do not transport the appliance without assistance.

4.4 Installing the appliance

In the event that the appliance is damaged, contact the supplier immediately before connecting to the mains.

The floor at the site must be flat and level.

Do not install the appliance in a location where it is exposed to direct radiation of the sun, next to a cooker, heater and similar.

Do not install the appliance without assistance.

Standard EN 378 specifies that the room in which you install your appliance must have a volume of 1 m³ per 8 g of R 600a refrigerant used in the appliance. If the room in which the appliance is installed is too small, a flammable gas-air mixture may form in the event of a leakage in the refrigeration circuit. The quantity of refrigerant used in your appliance is indicated on the type plate on the inside of the appliance.

Fit the appliance in stable kitchen units only.

The following ventilation gaps must be observed:

- ❑ The depth of the ventilation channel at the rear of the unit must be at least 38 mm.
- ❑ There must be a ventilation space of at least 200 cm² in the plinth and at the top of the unit.
- ❑ Basically the principle applies: the larger the ventilation space, the more energy-saving the appliance is in operation.



WARNING

Fire hazard due to dampness!

If live parts or the mains lead become damp this may cause short circuits.

- ▶ The appliance is designed for use in enclosed areas. Do not operate the appliance outdoors or in areas where it is exposed to splash water or damp conditions.



WARNING

Fire hazard due to refrigerant!

The refrigerant R 600a is environmentally friendly but flammable. Escaping refrigerant may ignite.

- ▶ Do not damage the piping of the refrigeration circuit.



WARNING

Fire hazard and danger of damage!

- ▶ Do not place appliances emitting heat e.g. microwaves, toasters etc. on the appliance!

- ▶ Detach the connecting cable from the rear of the appliance, removing the cable holder at the same time because otherwise there will be vibratory noise!

After installation:

- ▶ Remove the protective film from the decorative trims and drawer fronts.
- ▶ Remove all transit supports.
- ▶ Dispose of packaging material. See section on packaging disposal.

If the appliance is installed in a very damp environment, condensate may form on the outside of the appliance.

- ▶ Always see to good ventilation at the installation site.

4.5 Disposing of packaging



WARNING

Danger of suffocation due to packing material and plastic film!

- ▶ Do not allow children to play with packing material.

The packaging is made of recyclable materials:

- corrugated board/cardboard
- EPS moulded parts
- polythene bags and sheets
- polypropylene straps

- ▶ Take the packaging material to an official collecting point.



4.6 Connecting the appliance

ATTENTION

Risk of damage to the electronic control system!

- ▶ Do not use stand-alone inverters (conversion of d.c. to a.c./three-phase) or energy saving plugs.

**WARNING**

Fire and overheating hazard!

- ▶ Do not use extension cables or multiple socket outlets.

The type of current (alternating current) and voltage at the installation site have to conform with the data on the type plate (see section on description of appliance and equipment).

Connect the appliance only with a properly installed socket outlet with earthing contact. The socket outlet must be fused with 10 A or higher.



- ▶ Check the electrical connection.
- ▶ Clean the appliance. More information on this is in the section on cleaning.
- ▶ Plug in the power plug.

4.7 Switching on the appliance

Note

- ▶ To switch on the entire appliance it is necessary only to switch on the freezer compartment.

Note*

- ▶ After switch-on, first the freezer compartment is cooled and after some time the refrigerator compartment.

Put the appliance into operation about 2 hours before first loading food to be frozen.

Do not load food to be frozen before the temperature display reads -18 °C.

4.7.1 Switching on the freezer compartment

- ▶ Press On/Off button, freezer compartment (3).
- ▷ The refrigerator compartment temperature display shows the set temperature.
- ▷ The freezer compartment temperature display and the alarm button flash until the temperature is sufficiently cold. If the temperature is above 0 °C, dashes flash. If it is below, the current temperature flashes.

4.7.2 Switching on the refrigerator compartment

- ▶ Press On/Off button, refrigerator compartment (11).
- ▷ The interior light is on when the door is open.
- ▷ The temperature display shines. The refrigerator compartment is switched on.

5 Control

5.1 Saving energy

- ▶ Always pay attention to good ventilation.
- ▶ Keep the time the appliance is open to a minimum.
- ▶ Store food logically.
- ▶ Defrost frozen food in the refrigerator.
If there is a thick layer of frost in the appliance:
▶ defrost the appliance.*

5.2 Brightness of the temperature display

You can adjust the brightness of the temperature display to the light conditions of the room in which the appliance is installed.

5.2.1 Adjusting the brightness

The brightness is adjustable between h1 (no illumination) and h5 (maximum luminosity).

- ▶ To activate the setting mode: press the SuperFrost button (2) for about 5 s.
- ▷ The display indicates e.
- ▷ The SuperFrost button flashes.
- ▶ Using the Up setting button, freezer compartment (5) or Down setting button, freezer compartment (4) select h.
- ▶ To confirm: briefly press the SuperFrost button (2).
- ▶ To make the display brighter: press Up button, freezer compartment (5).
- ▶ To make the display darker: press Down button, freezer compartment (4).
- ▶ To confirm: press SuperFrost button (2).
- ▷ The brightness is adjusted to the new value.
- ▶ To deactivate the set-up mode: press On/Off button, freezer compartment (3).



-or-

- ▶ Wait for 5 minutes.
- ▷ The temperature is indicated again in the temperature display.

5.3 Child proofing

The child-proofing function enables you to make sure that the appliance is not inadvertently switched off by playing children.

5.3.1 Setting the child lock

- ▶ To activate the setting mode: press SuperFrost button (2) for about 5 s.
- ▷ The display indicates e.
- ▷ The SuperFrost button flashes.
- ▶ Briefly press the SuperFrost button (2) to confirm.
- ▶ To switch on: Using the Up setting button, freezer compartment (5) or Down setting button, freezer compartment, (4) select e1.
- ▶ To switch off: Using the Up setting button, freezer compartment (5) or Down setting button, freezer compartment, (4) select e0.
- ▶ To confirm: press SuperFrost button (2).
- ▷ When the child lock symbol (8) shines, the child lock is activated.
- ▶ To deactivate the set-up mode: press On/Off button, freezer compartment (3).



-or-

- ▶ Wait for 5 minutes.
- ▷ The temperature is indicated again in the temperature display.

5.4 Door alarm

For refrigerator and freezer compartment

If the door is open longer than 60 s, the audible alarm sounds.

The audible alarm is automatically silenced when the door is closed.

5.4.1 Muting the door alarm

The audible alarm can be muted when the door is open. The sound switch-off function is active as long as the door is left open.

- ▶ Press alarm button (1).
- ▷ The door alarm is silenced.

5.5 Temperature alarm

The audible alarm sounds if the freezer temperature is not cold enough.

The temperature display flashes at the same time.

The cause of the temperature being too high may be:

Control

- warm fresh food was placed inside
- too much warm ambient air flowed in when rearranging and removing food
- power failure for some time
- the appliance is faulty

The audible alarm is automatically silenced and the temperature display stops flashing when the temperature is sufficiently cold again.

If the alarm status persists, proceed as indicated in the section on troubleshooting.

Note

Food may be spoilt if the temperature is not cold enough.

- ▶ Check the quality of the food. Do not consume spoiled food.

5.5.1 Muting the temperature alarm

The audible alarm can be muted. When the temperature is sufficiently cold again, the alarm function is active again.

- ▶ Press alarm button (1).
- ▷ The audible alarm is silenced.

5.6 Refrigerator compartment

The natural circulation of air in the refrigerator compartment results in zones differing in temperature. It is coldest directly above the vegetable drawers and at the rear wall. It is warmest at the top front of the compartment and in the door.

5.6.1 Food refrigeration

Note

The energy consumption increases and the cooling performance decreases if the ventilation is inadequate.

- ▶ Always keep the air slits of the fan free.

- ▶ Store perishable food such as ready-to-serve dishes, meat products and sausages in the coldest zone. Place butter, eggs and preserves in the upper area and in the door. (see also the section on the appliance at a glance)
- ▶ Use recyclable plastic, metal, aluminium and glass containers and cling film for wrapping.
- ▶ Use the front area of the refrigerator compartment floor only for briefly putting down cooled products, e.g. when rearranging and sorting. However do not leave cooled products there otherwise they may be pushed back or tipped over when the door is closed.
- ▶ Do not store food too close together to enable good air circulation.
- ▶ To safeguard bottles from tipping over: move the bottle holder.

5.6.2 Setting the temperature in the refrigerator compartment

The temperature can be set from 11 °C to 2 °C, the recommended temperature is 5 °C.

- ▶ For a higher temperature setting: press Up button, refrigerator compartment (10).
- ▶ For a lower temperature setting: press Down button, refrigerator compartment (9).
- ▷ The first time the button is pressed, the value set so far is indicated in the refrigerator compartment temperature display.
- ▶ To change the temperature in 1 °C steps: briefly press the button.
- ▶ To change the temperature continuously: hold down the button.
- ▷ The value is displayed flashing during the setting operation.
- ▷ The actual temperature is displayed about 5 s after the last press of a button. The temperature slowly adjusts to the new value.

5.6.3 SuperCool

With SuperCool you switch to the highest cooling performance to reach lower cooling temperatures. Use SuperCool to rapidly cool large amounts of food.

When SuperCool is activated, the fan runs.

The SuperCool function uses slightly more energy.

Cooling with SuperCool

- ▶ Briefly press SuperCool button (12).
- ▷ The SuperCool button (12) lights up.
- ▷ The cooling temperature drops to the coldest value. SuperCool is activated.
- ▷ SuperCool is automatically deactivated after 6 to 12 hours. The appliance continues to operate in the energy-saving, normal mode.

To prematurely deactivate SuperCool

- ▶ Briefly press SuperCool button (12).
- ▷ The SuperCool button (12) goes out.
- ▷ SuperCool is deactivated.

5.6.4 Fan

With the fan you can rapidly cool large quantities of fresh food or achieve a relatively even distribution of temperature across all the storage levels.

The forced-air cooling is to be recommended:

- at high room temperature (from approx. 30 °C)
- at high humidity

The forced-air cooling uses slightly more energy. To save energy, the fan switches off automatically when the door is open.

Switching on the fan

- ▶ Briefly press the fan button (13).
- ▷ The fan button shines.
- ▷ The fan is active. It switches on automatically when the compressor runs.

To switch off the fan

- ▶ Briefly press the fan button (13).
- ▷ The fan button goes out.
- ▷ The fan is switched off.

5.6.5 Relocating the shelves

The shelves have stops preventing them from being unintentionally pulled out.

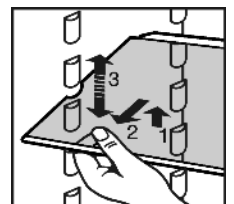

- ▶ Insert shelf with the raised edge pointing upwards at the back.
- ▷ The food does not freeze onto the rear wall.

5.6.6 Using the sectioned shelf

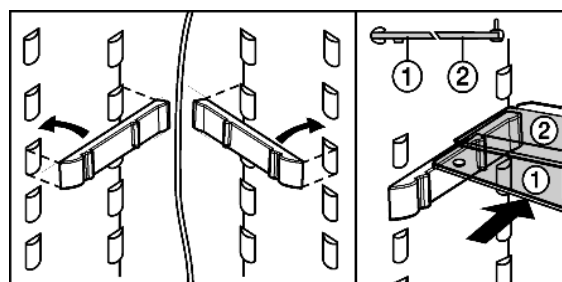
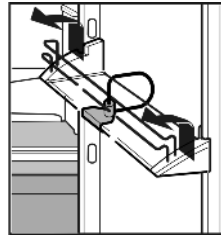

Fig. 32*

- ▶ The glass shelf with stop face (2) has to be at the back.

5.6.7 Moving the storage rack



Always remove the butter and cheese compartment together with the lid.

- ▶ To remove lid: Press one side part of the butter and cheese compartment outwards until the lid pin is clear and then remove the lid sideways.

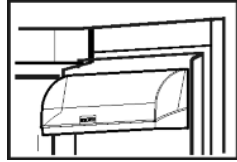

5.6.8 Removing the bottle holder

- ▶ Always take hold of the bottle holder on the plastic part.

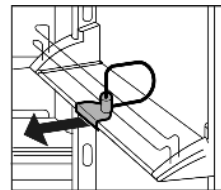

5.7 Freezer compartment

You can store frozen food, make ice cubes and freeze fresh food in the freezer compartment.

5.7.1 Freezing food

The maximum load for an individual drawer and the plate is 25 kg frozen food.

A vacuum is generated after the door is closed. After closing the door, wait for about 1 minute and then it opens more easily.



CAUTION

Risk of injury due to broken glass!
Bottles and cans containing drinks may burst when being frozen. This applies particularly to sparkling drinks.

- ▶ Do not freeze bottles and cans containing drinks!

In order that the food is rapidly frozen through to the core, do not exceed the following quantities per pack:

- Fruit, vegetables up to 1 kg
- Meat up to 2.5 kg
- ▶ Pack the food in portions in freezer bags, reusable plastic, metal or aluminium containers.

5.7.2 Thawing food

- in the refrigerator compartment
- at room temperature
- in a microwave oven
- in a conventional or fan oven
- ▶ Food once thawed should be re-frozen only in exceptional cases.

5.7.3 Setting the temperature in the freezer compartment

The appliance is pre-set for normal operation.

The temperature can be set between -16 °C and -26 °C / Australia model -14 °C and -26 °C, the recommended temperature is -18 °C.*

The temperature can be set between -16 °C and -26 °C, the recommended temperature is -18 °C.

- ▶ To set the temperature higher: press Up button, freezer compartment (5).
- ▶ To set the temperature lower: press Down button, freezer compartment (4).
- ▷ When the button is pressed the first time, the previous value is indicated in the temperature display of the freezer compartment.
- ▶ To change the temperature in 1 °C steps: briefly press the button.

-or-

- ▶ To change the temperature continuously: hold down the button.
- ▷ The value is displayed flashing during the setting operation.
- ▷ The actual temperature is displayed about 5 s after the last press of a button. The temperature slowly adjusts to the new value.

5.7.4 SuperFrost

With this function you can freeze fresh food quickly through to the core. The appliance operates with maximum refrigeration. The noise of the refrigeration unit may be temporarily louder as a result.

The maximum amount of fresh food which can be frozen in 24 h is indicated on the type plate under "freezing capacity ... kg/24h". This amount varies according to the model and climate rating.

Freezing with SuperFrost

You do not have to activate SuperFrost in the following cases:

- when placing frozen food in the freezer
- when freezing up to about 2 kg fresh food a day
- ▶ Briefly press the SuperFrost button (2) once.
- ▷ The SuperFrost button (2) shines.
- ▷ The freezer temperature drops, the appliance operates with maximum refrigerating performance.
- For a small amount of food:
 - ▶ wait about 6 h.
 - ▶ Place the fresh food in the top drawers.
- For the maximum amount of food:
 - ▶ wait about 24 h.
 - ▶ Place wrapped food straight on the shelves and, once frozen, put it into the drawers.
- ▷ SuperFrost is automatically deactivated. Depending on the quantity placed inside, after 30 h at the earliest, 65 h at the latest.*
- ▷ Freezing is concluded.
- ▷ The SuperFrost button (2) is dark.
- ▷ The appliance continues to operate in the energy-saving, normal mode.

5.7.5 Drawers

Note

The energy consumption increases and the cooling performance decreases if there is insufficient ventilation.

For appliances with NoFrost:

- ▶ Leave the bottom drawer in the appliance!
- ▶ Always keep the air slits of the fan free at the rear wall!

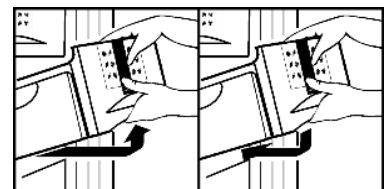

Control

- ▶ To store frozen food directly on the shelves: pull the drawer forwards and lift it out.

5.7.6 Shelves

- ▶ To remove the shelf: lift up at the front and pull out.
- ▶ To put the shelf back: simply push in as far as it will go.

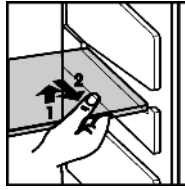

5.7.7 VarioSpace

Apart from being able to remove the drawers, you can also remove the shelves, creating space for large items of frozen food. Poultry, meat, large pieces of game and high bakery products can be frozen in one piece and prepared.

- ▶ The maximum load of frozen food for an individual drawer or shelf is 25 kg.

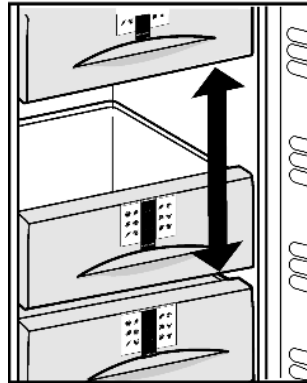

5.7.8 Information system

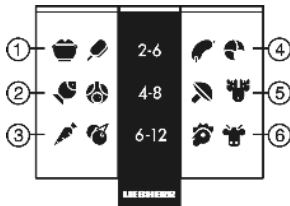

Fig. 33

- | | |
|---------------------------------|---------------------------|
| (1) Ready-made meals, ice cream | (4) Sausages, bread cream |
| (2) Pork, fish | (5) Game, mushrooms |
| (3) Fruit, vegetables | (6) Poultry, beef/veal |

The figures indicate the storage time in months for several types of frozen food in each case. Storage times given are guide times.

5.7.9 Freezer tray

The freezer tray allows you to freeze berries, herbs, vegetables and other small items of food without them sticking together. Items being frozen will largely retain their shape, and it will be easier to remove exactly the right quantity later on.

In addition, you can store the cold storage accumulators in the freezer tray to save space.

Using the freezer tray

- ▶ Spread the items out loosely on the freezer tray.
- ▶ Attach the freezer tray in one of the upper drawers.
- ▶ Allow the food to freeze through for 10 to 12 h.
- ▶ Transfer the frozen food to freezer bags or containers.
- ▶ Store freezer bags or containers in a drawer.
- ▶ To thaw the items, spread them out loosely again.

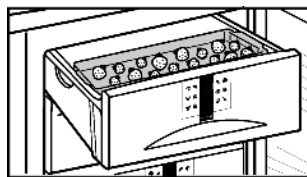

5.7.10 Cold storage accumulators

You can freeze and store the cold storage accumulators either in the freezer tray or in the ceiling of the freezer compartment, depending on type of appliance. *

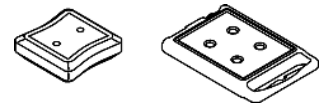

It is possible for cold storage accumulators to be frozen in the ceiling only in appliances without NoFrost module!*

With the top drawer removed:

- ▶ to insert cold storage accumulators: slide cold storage accumulator into the top back of the freezer compartment ceiling and snap into place at the front.

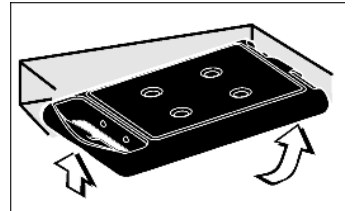

With the top drawer removed:

- ▶ to remove cold storage accumulators: take hold of the cold storage accumulator at the side and press it down for removal.

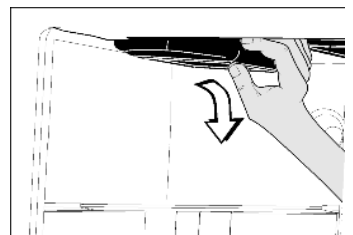

5.7.11 IceMaker*

The IceMaker is in the top drawer of the freezer compartment. The drawer is marked "IceMaker".

Make certain that the following conditions are met:

- The appliance is level.
- The appliance is connected.
- The freezer compartment is switched on.
- The IceMaker is connected to the water supply.

Switching on the IceMaker*

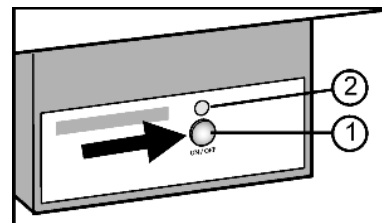

Fig. 34

- ▶ Pull out the drawer.
- ▶ Press the On/Off button Fig. 34 (1) so that the LED Fig. 34 (2) shines.
- ▶ Push in the drawer.

Note

- ▶ The IceMaker produces ice cubes only if the drawer is fully closed.

Switching off the IceMaker*

If no ice cubes are needed, the IceMaker can be switched off independently of the freezer compartment.

When the IceMaker is switched off, the IceMaker drawer can also be used for freezing and storing food.

- ▶ Press the On/Off button for about 1 second until the LED goes out.
- ▶ Clean the IceMaker.
- ▷ This ensures that no water or ice remains in the IceMaker.

Producing ice cubes*

The production capacity depends on the freezer temperature. The lower the temperature, the more ice cubes can be produced in a specific period.

The ice cubes drop out of the IceMaker into the drawer. When a certain filling level is reached, no more ice cubes are produced. If large quantities of ice cubes are needed, the complete IceMaker drawer can be exchanged for the adjacent drawer. When the drawer is closed, the IceMaker automatically re-commences production.

Once the IceMaker has been switched on for the first time, it may take up to 24 hours until the first ice cubes are produced.



CAUTION

Risk of damage to health!

- ▶ Do not consume or use the first three loads of ice cubes. This applies if the appliance is used for the first time and if it has been out of use for a long time. This ensures that the water line is thoroughly rinsed.

6 Maintenance

6.1 Defrosting with NoFrost*

The NoFrost system automatically defrosts the appliance.

Refrigerator compartment:

The defrost water evaporates due to the compressor heat. Drops of water on the rear wall are perfectly normal.

- ▶ Regularly clean the drain opening to allow the water to flow away. (see section on cleaning the appliance)

Freezer compartment:

The moisture condenses on the evaporator, is periodically defrosted and evaporates.

- ▶ The appliance does not have to be manually defrosted.

6.2 Manual defrosting*

The **refrigerator compartment** is defrosted automatically. The defrost water evaporates as a result of the heat of the compressor. Drops of water on the rear wall are perfectly normal.

- ▶ Regularly clean the drain opening to allow the water to flow away. (see section on cleaning)

A layer of frost or ice can build up in the **freezer compartment** after a long period of operation.

The layer of frost or ice builds up faster if the appliance is opened often or if the food is warm when placed inside. However, a thick layer of ice will increase the appliance's energy consumption. You should therefore defrost the appliance regularly.

- ▶ Switch on SuperFrost one day before defrosting.
- ▷ The frozen goods are provided with a "cold reserve".
- ▶ Switch off the appliance.
- ▷ The temperature display goes out.
- ▷ If the temperature display does not go out, the child lock function (see section on child lock) is active.
- ▶ Pull out the power plug or switch off the fuse.
- ▶ Place cold storage accumulators on top of the frozen food.
- ▶ If possible, put the frozen goods in the freezer drawer, wrapped in newspaper or a blanket, and store in a cool place.
- ▶ Place a pan with hot, not boiling water on a middle shelf.



-or-

- ▶ Half-fill the two lower drawers with lukewarm water and put them in the appliance.

- ▷ Defrosting is speeded up.
- ▷ Defrost water is collected in the drawers.
- ▶ Leave the door of the appliance open while defrosting.
- ▶ Pay attention that the defrost water does not run into the kitchen unit.
- ▶ If necessary, pick up defrost water several times, using a sponge or cloth.

- ▶ Clean the appliance (see section on cleaning) and rub dry.

6.3 Cleaning the appliance.

Before cleaning:



CAUTION

Risk of injury and damage as a result of hot steam! Hot steam may damage the surfaces and cause burns.

- ▶ Do not use any steam cleaners!

ATTENTION

Incorrect cleaning damages the appliance!

- ▶ Do not use cleaning agents in concentrated form.
- ▶ Do not use any scouring or abrasive sponges or steel wool.
- ▶ Do not use any cleaning agents containing sand, chloride, chemicals or acid.
- ▶ Do not use chemical solvents.
- ▶ Do not damage or remove the type plate on the inside of the appliance. It is important for the customer service.
- ▶ Do not pull off, bend or damage cables or other components.
- ▶ Do not allow any cleaning water to enter the drain channel, ventilation grille or electrical parts.

- ▶ Empty the appliance.
- ▶ Pull out the power plug.



- Use soft cleaning cloths and a multi-purpose cleaning agent with neutral pH value.
- Only use food compatible cleaning and care agents on the inside of the appliance.

Outside surfaces and interior:

- ▶ Clean the plastic surfaces, outside and inside, by hand using lukewarm water and a little washing-up liquid.
- ▶ To clean the drain opening: remove any deposits with a fine instrument, e.g. a cotton bud.

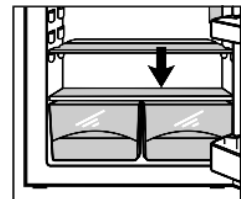

Items of equipment:

- ▶ Clean items of equipment by hand with lukewarm water and a little washing-up liquid.
- ▶ For cleaning, remove the support rails for the half-sized glass shelves.
- ▶ To dismantle the shelves: remove the trims and side parts.
- ▶ To dismantle the storage rack: remove the protective film from the decorative trims.

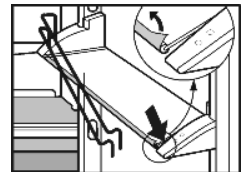

After cleaning:

- ▶ Wipe dry the appliance and items of equipment.
- ▶ Connect the appliance and switch it on again.
- ▶ Activate SuperFrost . (see section on SuperFrost)
- When the temperature is sufficiently cold:
- ▶ Put the food back inside.

Malfunction

6.4 Cleaning the IceMaker*

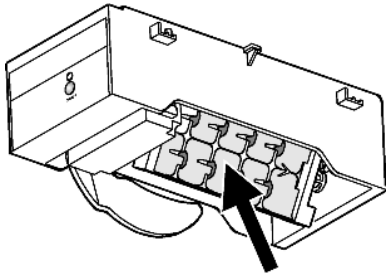

Fig. 35

The IceMaker has to be switched on.

- ▶ Pull out the drawer and remove the ice cubes.
- ▶ Clean the drawer with warm water and mild washing-up liquid.
- ▶ When the drawer is pulled out, hold down the On/Off button (about 10 seconds).
- ▷ After about 1 s the LED goes out, the IceMaker is switched off.
- ▷ After about 10 s the LED flashes for about 60 s.
- ▶ Slide in the drawer while the LED is flashing.
- ▷ The ice-cube tray of the IceMaker turns to a skew position.
- ▶ Remove the drawer.
- ▶ Clean the ice cube tray with warm water. If necessary, use mild washing-up liquid. Then rinse.
- ▶ Switch the IceMaker on again.
- ▶ Press the ON/OFF button until the LED shines, then slide in the drawer.
- ▷ The IceMaker starts producing ice cubes.
- ▶ If washing-up liquid was used:
- ▶ throw away the first three loads of ice cubes to get rid of any remaining washing-up liquid.

6.5 Customer service

First check whether you can correct the fault yourself by reference to the list in the section on troubleshooting. If this is not the case, please contact the customer service whose address is given in the enclosed customer service list.



WARNING

Risk of injury if repair work is not carried out professionally!

- ▶ Have any repairs to and intervention in the appliance and mains power cable, which are not expressly mentioned in the section on maintenance, carried out by the customer service only.

- ▶ Read the appliance designation Fig. 36 (1), service No. Fig. 36 (2) and serial No. Fig. 36 (3) off the type plate located inside the appliance on the left-hand side.

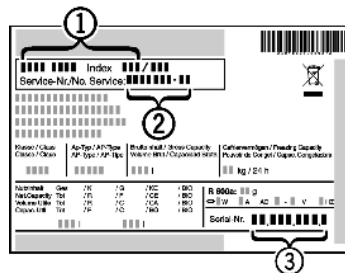

Fig. 36

- ▶ Notify the customer service, specifying the fault, appliance designation Fig. 36 (1), service No. Fig. 36 (2) and serial No. Fig. 36 (3).
- ▷ This will help us to provide you with a faster and more accurate service.
- ▶ Keep the appliance closed until the customer service arrives.
- ▷ The food will stay cool longer.
- ▶ Pull out the mains plug (not by pulling the connecting cable) or switch off the fuse.

7 Malfunction

Your appliance is designed and manufactured for a long life span and reliable operation. If a malfunction nonetheless occurs during operation, check whether it is due to a handling error. In this case you will have to be charged for the costs incurred, even during the warranty period. You may be able to rectify the following faults yourself:

Appliance does not work.

- The appliance is not switched on.
- ▶ Switch on the appliance.
- The power plug is not properly inserted in the wall socket.
- ▶ Check power plug.
- The fuse of the wall socket is not in order.
- ▶ Check fuse.

The compressor runs for a long time.

- The compressor switches to a low speed when little cold is needed. Although the running time is increased as a result, energy is saved.
- ▶ This is normal in energy-saving models.
- SuperFrost is activated.
- ▶ The compressor runs for longer in order to rapidly cool the food. This is normal.
- SuperCool is activated.
- ▶ The compressor runs for longer in order to rapidly cool the food. This is normal.

A bubbling and gurgling noise

- This noise comes from the refrigerant flowing in the refrigeration circuit.
- ▶ The sound is normal.

A quiet clicking noise

- The noise is produced whenever the refrigeration unit (motor) automatically switches on or off.
- ▶ The sound is normal.

A hum. It is briefly a little louder when the refrigeration unit (the motor) switches on.

- The refrigeration increases automatically when the SuperFrost, function is activated, fresh food has just been placed in the appliance or the door has been left open for a while.
- ▶ The sound is normal.
- The refrigeration increases automatically when the SuperCool function is activated, fresh food has just been placed in the appliance or the door has been left open for a while.
- ▶ The sound is normal.
- The ambient temperature is too high.
- ▶ See section on range of appliance use

A low hum

- The sound is produced by air flow noise of the fan.
- ▶ The sound is normal.

Vibratory noise

- The appliance is not standing firmly on the floor. As a result, adjoining units or objects are set into vibration by the running refrigeration unit.
- ▶ Move bottles and containers apart.

Flow sound at the soft stop mechanism.

- The noise is produced when the door is opened and closed.
- ▶ The sound is normal.

The temperature display indicates: F0 to F5.

- There is a fault.
- ▶ Contact the customer service. See the section on maintenance.

The temperature display indicates: nR

- The freezer temperature rose too high over the last hours or days due to a power failure or power interruption. When the power interruption is over, the appliance will continue to operate in the last temperature setting.

- ▶ Press alarm button (1).
- ▷ The warmest temperature reached during the power failure will appear in the temperature display for about 60 s. After that, the actual temperature in the freezer will re-appear.
- ▶ To prematurely cancel the display of the warmest temperature: press alarm button (1).
- ▶ Check the quality of the food. Do not consume spoiled food. Do not re-freeze thawed food.

The IceMaker cannot be switched on. *

- The appliance and therefore the IceMaker are not connected.
- ▶ Connect the appliance. See also the section on connection.

The IceMaker does not make any ice cubes.*

- The IceMaker is not switched on.
- ▶ Switch on the IceMaker.
- The drawer of the IceMaker is not properly closed.
- ▶ Close the drawer properly.
- The water connection is not open.
- ▶ Open the water connection.

The temperature is not cold enough.

- The door of the appliance is not properly closed.
- ▶ Close the door of the appliance.
- Insufficient ventilation.
- ▶ Clear ventilation grilles.
- The ambient temperature is too high.
- ▶ See section on operating conditions of the appliance.
- The appliance was opened too frequently or for too long.
- ▶ Wait until the appliance reaches the required temperature itself. If not, contact the customer service. See the section on maintenance.
- Too much fresh food was placed inside without SuperFrost.
- ▶ See section on SuperFrost.
- The temperature is incorrectly set.
- ▶ Set to a colder temperature and check after 24 h.
- The appliance is too close to a heat source.
- ▶ See the section on installation.

The interior light is not on.

- The appliance is not switched on.
- ▶ Switch on the appliance.
- The door was open longer than 15 min.
- ▶ The interior light automatically switches off if the door has been open for about 15 min.
- The LED interior lighting is faulty or the cover is damaged:



WARNING

Risk of injury due to electric shock!
Live parts are located under the cover.

- ▶ Have the LED interior light changed or repaired only by the customer service or by specialized personnel trained for the purpose.



WARNING

Danger of injury due to laser radiation, class 1M.

- ▶ Do not look inside when the cover is open.

8 Decommissioning

8.1 Switching off the appliance

Note

- ▶ To switch off the entire appliance it is necessary only to switch off the freezer compartment.

8.1.1 Switching off the freezer compartment

- ▶ Press On/Off button, freezer compartment (3) for about 2 s.
- ▷ The temperature displays are dark. The appliance is switched off.

8.1.2 Switching off the refrigerator compartment

Note

- ▶ The refrigerator compartment can be switched off separately, if required.

- ▶ Press On/Off button, refrigerator compartment (11) for about 2 s.
- ▷ The temperature display of the refrigerator compartment (7) is dark. The refrigerator compartment is switched off.

8.2 Taking the appliance out of service

- ▶ Empty the appliance.
- ▶ Put the IceMaker in the cleaning position. (see section on cleaning IceMaker)*
- ▶ Pull out the power plug.
- ▶ Clean the appliance (see section on cleaning).



- ▶ Leave the door open to prevent odour.

9 Disposing of the appliance

The appliance contains some reusable materials and should be disposed of properly - not simply with unsorted household refuse. Appliances which are no longer needed must be disposed of in a professional and appropriate way, in accordance with the current local regulations and laws.



When disposing of the appliance, ensure that the refrigeration circuit is not damaged to prevent uncontrolled escape of the refrigerant it contains (data on type plate) and oil.

- ▶ Disable the appliance.
- ▶ Pull out the plug.
- ▶ Cut through the connecting cable.

