

Gebrauchsanleitung

Gefrierschrank

D

Operating instructions

Freezer

GB

Gebruiksaanwijzing

Diepvrieskast

NL

Mode d'emploi

Congelateur

F

Istruzione d'uso

Congelatore

I

Instrucciones de manejo

Congelador

E

Manual de utilização

Congelador

P

Kullanım kılavuzu

Derin dondurucu

TR

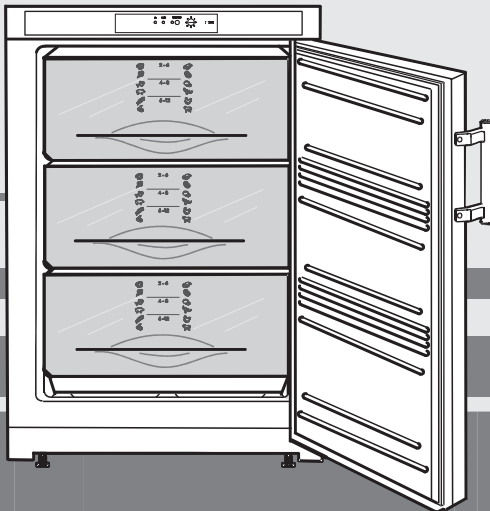

7080 906-00

G 12....

5010

Disposal notes

The packaging is made of recyclable materials.

- Corrugated board/board
- EPS moulded parts
- Polythene sheets
- Polypropylene straps

- **Keep packaging materials away from children - polythene sheets and bags can cause suffocation!**
- Please return the packaging to an official collection point.

Your old appliance: This contains some reusable materials and should be disposed of properly - not simply with unsorted household refuse.



- Discarded appliances should be disabled: Remove the plug, cut through the connection cable and render the catch unusable so that children cannot become trapped inside.
- Ensure that the refrigerant circuit is not damaged when the appliance that is no longer needed is taken away for disposal.
- Details of the refrigerant can be found on the type plate.
- Appliances which are no longer needed must be disposed of in a professional and appropriate way, in accordance with the current local regulations and laws.

Contents

	Page
Setting up, Connecting to the mains	
Saving energy, Dimensions	
Switching the appliance on and off	
Setting the temperature	
The red warning-LED	7
Notes on freezing and storage	
Freezing, storage	
Defrosting, Cleaning.....	8
Malfunctions, Shutting down	
Changing over door hinges.....	9

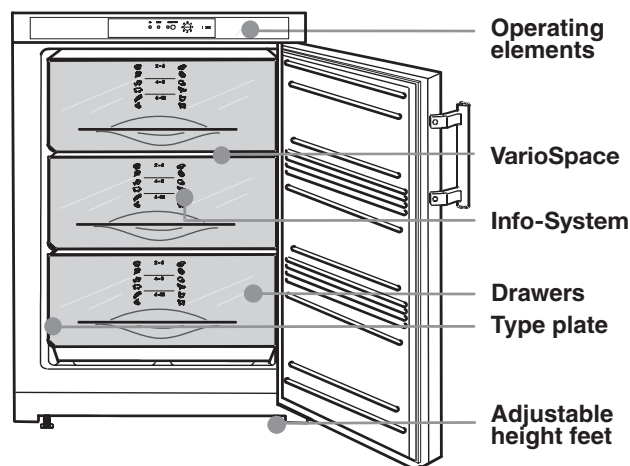

Safety instructions and warnings

- To prevent injury or damage to the unit, the appliance should be unpacked and set up by two people.
- In the event that the appliance is damaged on delivery, contact the supplier immediately before connecting to the mains.
- To guarantee safe operation, ensure that the appliance is set up and connected as described in these operating instructions.
- Disconnect the appliance from the mains if any fault occurs. Pull out the plug, switch off or remove the fuse.
- When disconnecting the appliance, pull on the plug, not on the cable.
- Any repairs and work on the appliance should only be carried out by the customer service department, as unauthorised work could prove highly dangerous for the user. The same applies to changing the mains power cable.
- Do not allow naked flames or ignition sources to enter the appliance. When transporting and cleaning the appliance ensure that the refrigerant circuit is not damaged. In the event of damage, make sure that there are no ignition sources nearby and keep the room well ventilated.
- Do not stand on the plinth, drawers or doors or use them to support anything else.
- This appliance is not intended for use by persons (including children) with reduced physical, sensory or mental capabilities or lack of experience and knowledge unless they have been given initial supervision or instruction concerning use of the appliance by a person responsible for their safety. Children should be supervised to ensure that they do not play with the appliance.
- Avoid prolonged skin contact with cold surfaces or chilled/frozen food. This could cause pain, numbness and frostbite. In the case of prolonged skin contact, protective measures should be taken, e.g. gloves should be worn.
- Do not eat ice cream, particularly ice lollies or ice cubes, immediately after taking them from the freezer compartment as there is a risk of "burning" because of the very cold temperatures.
- Do not consume food which has been stored for too long, as it could cause food poisoning.
- The device is designed exclusively for the cooling of foodstuffs. The applicable statutory regulations are to be observed in the event that the device is to be used for commercial cooling of foodstuffs.
- The device is not suitable for the storage and cooling of drugs, blood plasma, laboratory preparations or similar medicine-related materials and products as detailed in the Medical Devices Directive 2007/47/EC. Improper use of the device can cause the stored products stored in it to be damaged or the items can be spoiled. In addition, the device is not suitable for operation in explosion-prone areas.
- Do not store explosives or sprays using combustible propellants such as butane, propane, pentane etc. in the appliance. Electrical components might cause leaking gas to ignite. You may identify such sprays by the printed contents or a flame symbol.
- Do not use electrical appliances inside the appliance.

This instruction describes many models of appliances. Please bear in mind that individual models may differ slightly from these instructions.

Climate rating

The appliance is set to operate within specific ambient temperature limits according to its climate rating. These temperature limits should not be exceeded. The correct climate rating for your appliance is indicated on the type plate.

Climate rating Ambient temperatures

SN, N	up to +32 °C
ST	up to +38 °C
T	up to +43 °C

- The appliance will function properly in ambient temperatures of down to +5°C.

Setting up

- The floor on which the appliance stands should be horizontal and level. To compensate for any unevenness, adjust the height of the feet with an open-ended wrench.
- Always position the appliance directly up against the wall.
- The ventilation grilles should not be obstructed.
- Condensation may form on the outside of the refrigerator/freezer during periods of high humidity. Constant ventilation of the installation site is recommended.
- Keep burning candles, lamps and other items with naked flames away from the appliance so that they do not set the appliance on fire.
- In order to avoid the risk of fire, do not place any burning candles, lamps or other objects with open flames on the refrigerator/freezer.
- Standard EN 378 specifies that the room in which you install your appliance must have a volume of 1 m³ per 8 g of R 600a refrigerant used in the appliance, so as to avoid the formation of inflammable gas/air mixtures in the room where the appliance is located in the event of a leak in the refrigerant circuit. The quantity of refrigerant used in your appliance is indicated on the type plate on the inside of the appliance.
- Fire hazard due to dampness!
If live parts or the mains lead become damp this may cause short circuits.
- The appliance is designed for use in enclosed areas. Do not operate the appliance outdoors or in areas where it is exposed to splash water or damp conditions.
- CAUTION! Risk of injury and danger of damage as a result of incorrect transport!
 - Transport the appliance in a packed condition.
 - Transport the appliance upright.
 - Do not transport the appliance without assistance.
- The appliance may be moved only when it is empty.

Connecting to the mains

- Power supply (a.c.) and voltage at the operating point must comply with the details on the type plate which is located on the left-hand inside wall, next to the top freezer drawer. The socket must be fused with a 10 A fuse or higher. The socket should be easily accessible and not directly behind the appliance.
- Do not connect the appliance to the supply with other equipment using a distribution outlet - risk of overheating.
 - **Connect the appliance through a properly earthed plug and socket.**

Dimensions (mm) G 1221

h	a	g	e	e'	d	c	c'
851	553	610	624	653	1129	563	592

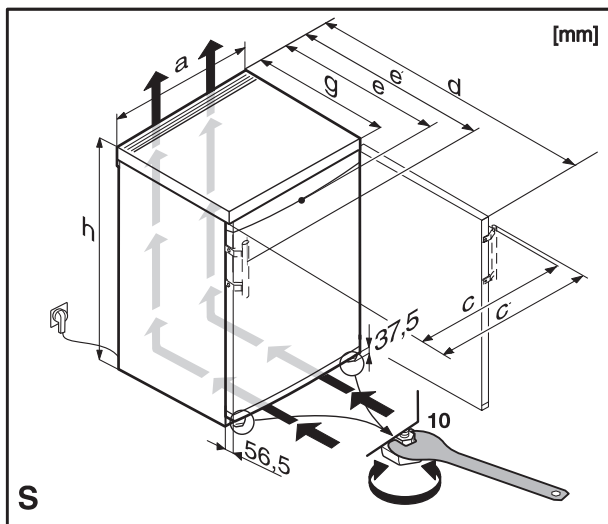

Saving energy

- Always ensure good ventilation. Do not cover ventilation openings or grille.
- Do not place appliance in areas of direct sunlight or next to a stove, heater or similar object.
- The energy consumption depends on the installation conditions, e.g. the ambient temperature.
- Keep the appliance open to a minimum.
- The lower the temperature setting, the higher the power consumption.
- Store food logically.
- Ensure that all food is well packed and covered for storage. This will prevent frost from forming.
- Remove food as needed in order that it does not warm too much.
- First cool warm food to room temperature before storing it.
- If there is a thick layer of frost in the appliance: defrost the appliance. Accumulated dust increases the energy consumption:
- Once a year, dust the refrigerating unit together with the metal grille of the heat exchanger at the back of the appliance.



Switching the appliance on and off

- You are recommended to clean the appliance before switching it on for the first time (see "Cleaning"). Switch the appliance on 4 hours before loading it with frozen food for the first time.
- Off:** Using a coin, turn the arrow on the temperature control ① to a setting between "1" and "6".
- The green ON-LED ② is lit.
 - The red warning-LED ③ twinkle up.
 - The red warning-LED is unlit as soon as the freezer compartment is cold enough (see "Red warning-LED").

To switch the appliance off: Turn the arrow on the temperature control ① to "0". The visual control-LED are unlit.

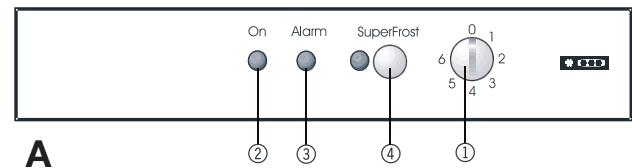

Setting the temperature

Setting "1" = lowest cooling setting, warm
Setting "6" = highest cooling setting, cold

- We recommend a **medium** setting.
- If you are storing frozen food and wish to ensure that the low freezing temperature is maintained, we recommend setting the temperature control to between "4" and "6".
- For long-term storage of frozen food a temperature of at least -18°C is recommended. Remember that the temperature depends on the ambient temperature (location of appliance), the number of times the door is opened and how much frozen food is stored. The setting should be adjusted accordingly if necessary.

The red visual warning LED

The red warning-LED ③ lits up if the temperature in the freezer compartment is not cold enough, i.e. when the temperature is above -8°C.

If the red warning-LED comes on during normal operation, check:

- whether there has been a lengthy interruption to the power supply; check the quality of the frozen food and prepare for consumption if necessary,
- whether the door is properly shut,
- whether fresh food has recently been inserted.

If none of the above apply, consult your nearest customer service department as soon as possible, giving details of the **type of appliance, index and service number**.

Notes on freezing and storage

- As a guideline for the storage time, the following applies to various foodstuffs in the freezer compartment:

Ice cream	2 to 6 months
Sausage, ham	2 to 6 months
Bread, cakes and pastries	2 to 6 months
Game, pork	6 to 10 months
Fish, oily	2 to 6 months
Fish, lean	6 to 12 months
Cheese	2 to 6 months
Poultry, beef	6 to 12 months
Vegetables, fruit	6 to 12 months

- Pack food which you are freezing yourself in quantities appropriate to your household. To ensure that the food freezes right through, the following quantities should not be exceeded per package: fruit, vegetables: up to 1 kg, meat: up to 2,5 kg.
- Blanch vegetables after washing and cutting them. (Add to boiling water for 2-3 minutes, remove and quickly cool down in cold water).
- Do not salt or season fresh food or blanched vegetables before freezing. Only lightly salt and season other food. The intensity of flavour of some spices can change.
- Suitable packaging materials are conventional freezer bags, reusable plastic, metal and aluminium containers.
- Do not allow fresh food which is to be frozen to come into contact with food already frozen. Always keep packs dry in order to avoid them sticking together.
- Always write the date and contents on the pack and do not exceed the stated storage time for the food.
- Do not freeze bottles and cans which contain carbonated drinks as they might burst.
- Only take out as much food as is immediately required for thawing. Use food which has been thawed in prepared meals as quickly as possible.

Frozen food can be thawed in the following ways:













- in a fan oven
- in a microwave oven
- at room temperature
- in the refrigerator; the cold given off by the frozen food is used for cooling.

Solid cuts of meat and fish can be cooked when partly thawed. Vegetables can be cooked from frozen (in half the normal time).

Info-System

Use frozen food within the recommended period. The numbers between the symbols indicate the storage period in months for different kinds of frozen foods.

Storage times given are guide times for food frozen at home. Whether or not the lower or upper value is applicable depends on the food quality and how it was pro-cessed prior to freezing. The lower values always apply to food with a high fat content. The symbols have the following signification:

pre-cooked meals		2 - 6		sausages
ice-cream				bread
fish		4 - 8		mushrooms
pork				game
vegetables		6 - 12		poultry
fruit				beef/veal

Freezing, storage

Fresh food should be frozen to the core as rapidly as possible. This ensures that the nutritional value, appearance and flavour of the food remains intact.

The maximum amount of food which can be frozen in 24 hours is shown on the type plate ("Freezing capacity ④ ...kg/24 hours"). This amount varies according to the model and climate rating.

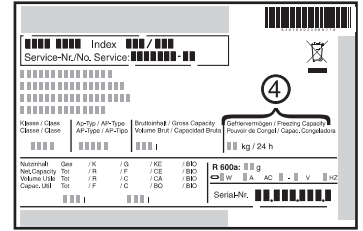

Freezing with Superfrost Fig. A

- Press Superfrost button ④ briefly, so that the LED lights up.
 - The freezing temperature decreases, the appliance works with the greatest possible freezing capacity, at the same time the LED is lit.
 - Then insert the fresh food.
 - With a small amount of food to be frozen, wait/pre-freeze approx. 6 hours, with the *maximum* amount, see rating plate under freezing capacity, approx. 24 hours. Then the Superfrost function can be switched off manually.
 - Superfrost switches off **automatically** after approx. 60 hours. The freezing process is complete.
 - the Superfrost LED is unlit** – the appliance works again in normal energy-saving mode of the last setting.
- Note:* You *do not* have to switch Superfrost on:
- when inserting food which is already frozen,
 - when freezing up to approx. 2 kg of fresh food per day.

Storage

When storing pre-frozen food, the freezer compartment can be filled straight away. It is not necessary to change the temperature setting.

Defrosting

- Switch the appliance off to defrost. Pull out the mains plug or set the temperature control to "0".
- Remove drawers and glass trays
- Wrap the frozen food in paper or blankets and store in a cool place.
- To speed up the defrosting process put a saucepan of hot water onto the bottom of the compartment.
- Leave the door of the appliance open while defrosting. After defrosting mop up the remaining water and clean the appliance.

Do not use any mechanical devices or other artificial aids for defrosting other than those recommended by the manufacturer.

Cleaning

Before cleaning always switch off the appliance. Pull out the mains plug or remove/unscrew the fuse.

Clean the inside, equipment parts and outer walls with lukewarm water and a little detergent. Do not use abrasive or acid cleaners or chemical solvents.

Do not use steam cleaners because of the risk of injury and damage.

- Ensure that no cleaning water penetrates into the electrical components or ventilation grille.
- Dry all parts well with a cloth.
- Do not damage or remove the type plate on the inside of the appliance. It is very important for servicing purposes.

